

YANMAR[®]

LV series

OPERATION MANUAL

**L48V
L70V
L100V**

P/N: 0ALV00-U0000

**INDUSTRIAL
ENGINES**

Disclaimers:

We reserve the right to change specifications and to improve our products without notice or obligation.

Yanmar and **YANMAR** are registered trademarks of Yanmar Co., Ltd. in Japan, the United States and / or other countries.

All Rights Reserved:

No part of this publication may be reproduced or used in any form by any means - graphic, electronic, or mechanical, including photocopying, recording, taping, or information storage and retrieval systems - without the written permission of Yanmar Co., Ltd.

© 2005 Yanmar Co. Ltd.

This Manual is Available in other Languages

EN

If you would like a copy of this manual in the English language, please contact your local authorized Yanmar industrial engine dealer or distributor. A list of authorized Yanmar industrial engine dealers and distributors can be found at:

<http://www.yanmar.co.jp/english/index-network.htm>

AR

هذا الكتيب متوفر بلغات اخرى. ان كنت ترغب بالحصول على نسخة باللغة العربية الرجاء الاتصال بالوكيل او الموزع المحلي المعتمد لشركة يانمار للمحركات الصناعية. يمكنك ان تجد قائمة باسمااء الوكلاء والموزعين المعتمدين لشركة يانمار للمحركات الصناعية في العنوان التالي:

<http://www.yanmar.co.jp/english/index-network.htm>

本手册提供其他语言版本

ZH

如果您需要本手册的中文版本，请与当地 Yanmar（洋马）工业引擎授权经销商或分销商联系。可从以下网址找到 Yanmar（洋马）工业引擎授权经销商或分销商名单：

<http://www.yanmar.co.jp/english/index-network.htm>

Tento návod je k dispozici i v dalších jazycích

CS

Pokud byste chtěli získat kopii tohoto návodu v českém jazyce, obraťte se, prosím, na svého místního autorizovaného prodejce nebo distributora průmyslových motorů Yanmar. Seznam autorizovaných prodejců a distributorů průmyslových motorů Yanmar lze nalézt na adrese:

<http://www.yanmar.co.jp/english/index-network.htm>

Denne håndbog kan fås på andre sprog

DA

Hvis du gerne vil have et eksemplar af denne håndbog på dansk, bedes du venligst kontakte den lokale autoriserede forhandler eller importør af Yanmar industrimotorer. En liste over autoriserede forhandlere og importører af Yanmar industrimotorer kan findes på:

<http://www.yanmar.co.jp/english/index-network.htm>

Deze handleiding is beschikbaar in andere talen

NL

Wilt u een exemplaar van deze handleiding in het Nederlands hebben, neemt u dan contact op met de dichtstbijzijnde officiële dealer of distributeur van industriemotoren van Yanmar. Kijk voor een lijst met officiële dealers of distributeurs van industriemotoren van Yanmar op:

<http://www.yanmar.co.jp/english/index-network.htm>

Ce manuel est disponible dans d'autres langues

FR

Si vous désirez une copie de ce manuel en français, veuillez contacter votre concessionnaire ou distributeur agréé de moteurs industriels Yanmar. Vous trouverez la liste des concessionnaires et distributeurs agréés de moteurs industriels Yanmar à l'adresse suivante:

<http://www.yanmar.co.jp/english/index-network.htm>

Tätä ohjekirjaa on saatavana muilla kielillä

FI

Jos haluat kappaleen tätä ohjekirjaa suomen kielellä, ota yhteys paikalliseen Yanmarin valtuuttamaan teollisuusmoottorien myynti- tai jakeluliikkeeseen. Luettelon valtuutetuista Yanmarin teollisuusmoottorien myynti- ja jakeluliikkeistä löydät osoitteesta:

<http://www.yanmar.co.jp/english/index-network.htm>

Dieses Handbuch steht in anderen Sprachen zur Verfügung

DE

Falls Sie gerne ein Exemplar dieses Handbuchs auf Deutsch hätten, wenden Sie sich bitte an Ihren autorisierten Fach- oder Vertriebshändler für Yanmar-Industriemotoren. Eine Liste autorisierter Fach- oder Vertriebshändler für Yanmar-Industriemotoren finden Sie unter:

<http://www.yanmar.co.jp/english/index-network.htm>

Το παρόν εγχειρίδιο διατίθεται και σε άλλες γλώσσες

EL

Για την ελληνική έκδοση του εγχειριδίου, παρακαλούμε επικοινωνήστε με τον τοπικό εξουσιοδοτημένο αντιπρόσωπο ή διανομέα των βιομηχανικών κινητήρων Yanmar. Επισκεφθείτε την παρακάτω διεύθυνση για να ενημερωθείτε για τους εξουσιοδοτημένους αντιπροσώπους ή διανομείς των βιομηχανικών κινητήρων Yanmar:

<http://www.yanmar.co.jp/english/index-network.htm>

A kézikönyv más nyelven is hozzáférhető

HU

Ha magyar nyelvű példányt szeretne, akkor kérjük, lépjen kapcsolatba a helyi meghatalmazott Yanmar iparimotor-kereskedővel vagy -forgalmazóval. A meghatalmazott Yanmar iparimotor-kereskedők és -forgalmazók listája a következő oldalon található:

<http://www.yanmar.co.jp/english/index-network.htm>

Il presente manuale è disponibile in altre lingue

IT

Se si desidera ricevere una copia di questo manuale in italiano, si prega di rivolgersi al concessionario o distributore autorizzato di motori industriali Yanmar di zona. L'elenco dei concessionari e distributori autorizzati di motori industriali Yanmar è disponibile al seguente indirizzo:

<http://www.yanmar.co.jp/english/index-network.htm>

本取扱説明書は各種言語版をご利用いただけます。

JA

日本語版の取扱説明書をご希望のお客様は、最寄りのヤンマー産業用エンジンの正規販売店または代理店にお問い合わせください。ヤンマー産業用エンジンの販売サービスネットワークについては、以下のサイトをご覧ください。

<http://www.yanmar.co.jp/english/index-network.htm>

Denne håndboken kan fås på andre språk

NO

Snakk med din Yanmar-forhandler hvis du vil ha denne håndboken på norsk. Du finner en liste over autoriserte forhandlere av Yanmar industrimotorer på:

<http://www.yanmar.co.jp/english/index-network.htm>

Ten podręcznik jest dostępny w innych językach

PL

Jeżeli potrzebny jest ten podręcznik w języku polskim, proszę skontaktować się z autoryzowanym miejscowym dealerem lub dystrybutorem przemysłowych silników Yanmar. Z wykazem autoryzowanych dealerów i dystrybutorów silników przemysłowych Yanmar można zapoznać się na stronie.

<http://www.yanmar.co.jp/english/index-network.htm>

Este Manual está Disponible noutros Idiomas

PT

Se desejar uma cópia deste manual em Português, por favor contacte o seu concessionário ou distribuidor autorizado de motores industriais Yanmar. É possível encontrar uma lista de concessionários e distribuidores autorizados de motores industriais Yanmar em:

<http://www.yanmar.co.jp/english/index-network.htm>

Настоящая инструкция по эксплуатации доступна и на других языках

RU

За экземпляром настоящей инструкции по эксплуатации на русском языке, пожалуйста обращайтесь к местному официальному дилеру или дистрибьютору промышленных двигателей Yanmar. Полный список официальных дилеров и дистрибьюторов промышленных двигателей Yanmar находится на сайте:

<http://www.yanmar.co.jp/english/index-network.htm>

Táto príručka je k dispozícii aj v iných jazykoch.

SK

Ak by ste chceli kópiu tejto príručky v Slovenskom jazyku, kontaktujte prosím svojho miestneho autorizovaného predajcu alebo distribútora priemyselných motorov Yanmar. Zoznam autozovaných predajcov a distribútorov priemyselných motorov Yanmar môžete nájsť na:

<http://www.yanmar.co.jp/english/index-network.htm>

Este manual está disponible en otros idiomas

ES

Si usted desea un ejemplar de este manual en español, por favor póngase en contacto con su concesionario o distribuidor local autorizado de motores industriales Yanmar. Puede encontrar una lista de los concesionarios y distribuidores autorizados de motores industriales Yanmar en:

<http://www.yanmar.co.jp/english/index-network.htm>

Denna handbok finns även på andra språk

SV

Om du vill få ett exemplar av denna handbok på svenska, vänligen kontakta närmaste behöriga återförsäljare eller distributör för Yanmar industrimotorer. En förteckning över godkända återförsäljare och distributörer för Yanmar industrimotorer finns på:

<http://www.yanmar.co.jp/english/index-network.htm>

Bu El Kitabı Başka Dillerdede Mevcuttur

TR

Bu el kitapçığının Türkçe'sini elde etmek istiyorsanız, lütfen bölgenizdeki Yanmar sanayi makineleri yetkili bayii dağıtımçısına başvurunuz. Yetkili Yanmar sanayi motor bayii ve dağıtımçileri listesini aşağıdaki Internet sayfasında bulabilirsiniz.

<http://www.yanmar.co.jp/english/index-network.htm>

INTRODUCTION

Welcome to the world of Yanmar Engines! Yanmar has been the leader in industrial diesel engines for over 90 years. We developed the world's first practical small-sized diesel engine in 1933. Our engineers are continuously developing new technology to keep Yanmar on the leading-edge of the industry. The LV Series engine is only one example of the new technology we have developed. We are committed to maintaining our environment, and are proud of our history of innovation, quality and respect for operator safety.

To help you enjoy your Yanmar LV Series engine for many years to come, please follow these recommendations:

- Read and understand this Operation Manual before you operate the machine to ensure that you follow safe operating practices and maintenance procedures.
 - Keep this Operation Manual in a convenient place for easy access.
 - If this Operation Manual is lost or damaged, order a new one from your authorized Yanmar industrial engine dealer or distributor.
 - Make sure this manual is transferred to subsequent owners. This manual should be considered a permanent part of the engine and remain with it.
- Constant efforts are made to improve the quality and performance of Yanmar products, so some details included in this Operation Manual may differ slightly from your engine. If you have any questions about these differences, please contact your authorized Yanmar industrial engine dealer or distributor.
 - The specifications and components (instrument panel, fuel tank, etc.) described in this manual may differ from ones installed on your machine. Please refer to the manual provided by the manufacturer of these components.

INTRODUCTION

RECORD OF OWNERSHIP

Take a few moments to record the information you need when you contact Yanmar for service, parts or literature.

Engine Model: _____

Engine Serial No.: _____

Date Purchased: _____

Dealer: _____

Dealer Phone: _____

YANMAR WARRANTIES

YANMAR LIMITED WARRANTY

What is Covered by this Warranty?

Yanmar warrants to the original retail purchaser that a new Yanmar LV Series Industrial Engine will be free from defects in material and / or workmanship for the duration of the warranty period.

THIS WARRANTY IS PROVIDED IN LIEU OF ALL OTHER WARRANTIES, EXPRESS OR IMPLIED. YANMAR SPECIFICALLY DISCLAIMS ANY IMPLIED WARRANTIES OF MERCHANTABILITY OR FITNESS FOR A PARTICULAR PURPOSE, except where such disclaimer is prohibited by law. IF SUCH DISCLAIMER IS PROHIBITED BY LAW, THEN IMPLIED WARRANTIES SHALL BE LIMITED IN DURATION TO THE LIFE OF THE EXPRESS WARRANTY.

How Long is the Warranty Period?

The Yanmar standard limited warranty period begins on the date of the delivery of the new Yanmar LV Series Industrial Engine to the first retail purchaser and extends for a period of **twenty-four (24) months or two-thousand (2000) engine operation hours**, whichever occurs first.

What the Engine Owner Must Do:

If you believe your Yanmar engine has experienced a failure due to a defect in material and / or workmanship, you must contact an authorized Yanmar industrial engine dealer or distributor within thirty (30) days of discovering the failure. You must provide proof of ownership of the engine, proof of the date of the engine purchase and delivery, and documentation of the Acceptable forms of proof of delivery date include, but are not limited to: the original warranty registration or sales receipts or other documents maintained in the ordinary course of business by Yanmar dealers and / or distributors, indicating the date of delivery of the Yanmar product to the original retail purchaser. This information is necessary to establish whether the Yanmar product is still within the warranty period. Thus, Yanmar strongly recommends you register your engine as soon as possible after purchase in order to facilitate any future warranty matters.

You are responsible for the transportation of the engine to and from the repair location as designated by Yanmar.

YANMAR WARRANTIES

Yanmar Limited Warranty - Continued

To Locate an Authorized Yanmar Industrial Engine Dealer or Distributor:

You can locate your nearest authorized Yanmar industrial engine dealer or distributor by visiting the Yanmar Corp., LTD. website at:

<http://www.yanmar.co.jp> (The Japanese language page will be displayed.) For English language “click” on “English Page.”)

- “Click” on “Network” in the web site heading to view the “Yanmar Worldwide Network.”
- Choose and “Click” on the desired product group.
- “Click” on the Icon closest to your region.
- “Click” on the desired country or Associate company to locate your nearest authorized Yanmar industrial engine dealer or distributor.
- You may also contact Yanmar by clicking on “Inquiry” in the web site heading and typing in your question or comment.

What Yanmar Will Do:

Yanmar warrants to the original retail purchaser of a new Yanmar engine that Yanmar will make such repairs and / or replacements at Yanmar’s option, of any part(s) of the Yanmar product covered by this Warranty found to be defective in material and/or workmanship. Such repairs and / or replacements will be made at a location designated by Yanmar at no cost to the purchaser for parts or labor.

What is Not Covered by this Warranty?

This Warranty does not cover parts affected by or damaged by any reason other than defective materials or workmanship including, but not limited to, accident, misuse, abuse, “Acts of God,” neglect, improper installation, improper maintenance, improper storage, the use of unsuitable attachments or parts, the use of contaminated fuels, the use of fuels, oils, lubricants, or fluids other than those recommended in your Yanmar Operation Manual, unauthorized alterations or modifications, ordinary wear and tear, and rust or corrosion. This Warranty does not cover the cost of parts and / or labor required to perform normal / scheduled maintenance on your Yanmar engine. This Warranty does not cover consumable parts such as, but not limited to, filters, belts, hoses, fuel injector nozzles, lubricants and cleaning fluids. This Warranty does not cover the cost of shipping the product to or from the warranty repair facility.

Yanmar Limited Warranty - Continued

Warranty Limitations:

The foregoing is Yanmar's only obligation to you and your exclusive remedy for breach of warranty. Failure to follow the requirements for submitting a claim under this Warranty may result in a waiver of all claims for damages and other relief. **In no event shall Yanmar or any authorized industrial engine dealer or distributor be liable for incidental, special or consequential damages.** Such consequential damages may include, but not be limited to, loss of revenue, loan payments, cost of rental of substitute equipment, insurance coverage, storage, lodging, transportation, fuel, mileage and telephone costs. The limitations in this Warranty apply regardless of whether your claims are based on breach of contract, tort (including negligence and strict liability) or any other theory. Any action arising hereunder must be brought within one (1) year after the cause of action accrues or it shall be barred. Some states and countries do not allow certain limitations on warranties or for breach of warranties. **This Warranty gives you specific legal rights, and you may also have other rights which vary from state to state and country to country.** Limitations set forth in this paragraph shall not apply to the extent that they are prohibited by law.

Warranty Modifications:

Except as modified in writing and signed by the parties, this Warranty is and shall remain the complete and exclusive agreement between the parties with respect to warranties, superseding all prior agreements, written and oral, and all other communications between the parties relating to warranties. **No person or entity is authorized to give any other warranty or to assume any other obligation on behalf of Yanmar, either orally or in writing.**

Questions:

If you have any questions or concerns regarding this Warranty, please call or write to the nearest authorized Yanmar industrial engine dealer or distributor or other authorized facility.

Retail Purchaser Registration

It is very important for the original retail purchaser to register the Yanmar product. Registration enables Yanmar to provide the best support for your Yanmar product.

At the time of purchase, Yanmar highly recommends registering the retail purchaser's information through website <http://www.yanmar.co.jp> as soon as possible.

If it is not possible to access the website, please contact the nearest authorized Yanmar industrial engine dealer or distributor.

YANMAR WARRANTIES

YANMAR CO., LTD. LIMITED EMISSION CONTROL SYSTEM WARRANTY - USA ONLY

Your Warranty Rights and Obligations:

California

The California Air Resources Board (CARB), the Environmental Protection Agency (EPA) and Yanmar Co., Ltd. hereafter referred to as Yanmar, are pleased to explain the **emission control system warranty** on your industrial compression-ignition engine. In California, model year 2000 or later off-road compression-ignition engines must be designed, built and equipped to meet the State's stringent anti-smog standards. In all states, 1998 and later non-road compression-ignition engines must be designed, built and equipped to meet the United States EPA emissions standards. Yanmar warrants the emission control system on your engine for the periods of time listed below provided there has been no abuse, neglect or improper maintenance of your engine.

Your emission control system may include parts such as the fuel injection system and the air induction system. Also included may be hoses, belts, connectors and other emission-related assemblies.

Where a warrantable condition exists, Yanmar will repair your non-road compression-ignition engine at no charge to you including diagnosis, parts and labor.

Manufacturer's Warranty Period:

The model year 1998 or later certified and labeled non-road compression-ignition engines are warranted for the periods listed below. If any emission-related part on your engine is found to be defective during the applicable warranty period, the part will be replaced by Yanmar.

Engine Type	Warranty Period by Number of Years or Hours of Operation
Constant speed engines rated at or above 50 hp SAE (37 kW)	The warranty period is five (5) years or 3,000 hours of use, whichever occurs first. In the absence of a device to measure the hours of use, the engine has a warranty period of five (5) years.
Constant speed engines rated under 50 hp SAE (37 kW) with rated speeds greater than or equal to 3,000 rpm	The warranty period is two (2) years or 3,000 hours of use, whichever occurs first. In the absence of a device to measure the hours of use, the engine has a warranty period of two (2) years.
Engines rated at or above 26 hp SAE (19 kW)	The warranty period is five (5) years or 3,000 hours of use, whichever occurs first. In the absence of a device to measure the hours of use, the engine has a warranty period of five (5) years.
Engines rated under 26 hp SAE (19 kW)	The warranty period is two (2) years or 3,000 hours of use, whichever occurs first. In the absence of a device to measure the hours of use, the engine has a warranty period of two (2) years.

Limited Emission Control System Warranty - USA Only - Continued

Warranty Coverage:

This warranty is transferable to each subsequent purchaser for the duration of the warranty period. Repair or replacement of any warranted part will be performed at an authorized Yanmar industrial engine dealer or distributor.

Warranted parts not scheduled for replacement as required maintenance in the Operation Manual shall be warranted for the warranty period. Warranted parts scheduled for replacement as required maintenance in the owner's manual are warranted for the period of time prior to the first scheduled replacement. Any part repaired or replaced under warranty shall be warranted for the remaining warranty period.

During the warranty period, Yanmar is liable for damages to other engine components caused by the failure of any warranted part during the warranty period.

Any replacement part which is functionally identical to the original equipment part in all respects may be used in the maintenance or repair of your engine, and shall not reduce Yanmar's warranty obligations. Add-on or modified parts that are not exempted may not be used. The use of any non-exempted add-on or modified parts shall be grounds for disallowing a warranty.

Warranted Parts:

This warranty covers engine components that are a part of the emission control system of the engine as delivered by Yanmar to the original retail purchaser. Such components may include the following:

- Fuel Injection System
- Cold Start Enrichment System
- Intake Manifold
- Turbocharger Systems
- Exhaust Manifold
- Positive Crankcase Ventilation System
- Hoses, belts, connectors and assemblies associated with emission control systems

Since emissions related parts may vary slightly between models, certain models may not contain all of these parts and other models may contain the functional equivalents.

YANMAR WARRANTIES

Limited Emission Control System Warranty - USA Only - Continued

Exclusions:

Failures other than those arising from defects in material and / or workmanship are not covered by this warranty. The warranty does not extend to the following: malfunctions caused by abuse, misuse, improper adjustment, modification, alteration, tampering, disconnection, improper or inadequate maintenance or use of non-recommended fuels and lubricating oils; accident-caused damage, and replacement of expendable items made in connection with scheduled maintenance. Yanmar disclaims any responsibility for incidental or consequential damages such as loss of time, inconvenience, loss of use of equipment / engine or commercial loss.

Owner's Warranty Responsibilities:

As the engine owner, you are responsible for the performance of the required maintenance listed in your owner's manual. Yanmar recommends that you retain all documentation, including receipts, covering maintenance on your non-road compression-ignition engine, but Yanmar cannot deny warranty solely for the lack of receipts, or for your failure to ensure the performance of all scheduled maintenance.

Yanmar may deny your warranty coverage of your non-road compression-ignition engine if a part has failed due to abuse, neglect, improper maintenance or unapproved modifications.

Your engine is designed to operate on diesel fuel only. Use of any other fuel may result in your engine no longer operating in compliance with applicable emissions requirements.

You are responsible for initiating the warranty process. You must present your engine to a Yanmar dealer as soon as a problem exists. The warranty repairs should be completed by the dealer as expeditiously as possible. If you have any questions regarding your warranty rights and responsibilities, or would like information on the nearest Yanmar dealer or authorized service center, you should contact Yanmar America Corporation at 1-800-872-2867.

TABLE OF CONTENTS

	Page
Introduction	v
Record of Ownership.....	vi
Yanmar Warranties	vii
Yanmar Limited Warranty.....	vii
What is Covered by this Warranty?	vii
How Long is the Warranty Period?	vii
What the Engine Owner Must Do:	vii
To Locate an Authorized Yanmar Industrial Engine Dealer or Distributor:	viii
What Yanmar Will Do:	viii
What is Not Covered by this Warranty?	viii
Warranty Limitations:.....	ix
Warranty Modifications:.....	ix
Questions:	ix
Retail Purchaser Registration.....	ix
Yanmar Co., Ltd. Limited Emission Control System Warranty - USA Only	x
Your Warranty Rights and Obligations:	x
Manufacturer’s Warranty Period:.....	x
Warranty Coverage:	xi
Warranted Parts:	xi
Exclusions:	xii
Owner’s Warranty Responsibilities:.....	xii
Table of Contents	xiii
Safety	1
Safety Statements	1
Safety Precautions	2
Before You Operate.....	2

TABLE OF CONTENTS

During Operation and Maintenance	2
Product Overview	15
Yanmar LV Series Engine Features and Applications	15
Component Identification.....	16
Location of Labels	17
EPA / ARB Emission Control Regulations - USA Only.....	18
Emission Control Labels - USA Only.....	18
EPA / ARB Labels	18
The 97/68/EC Directive Certified Engines.....	19
Engine Family.....	19
Function of Major Engine Components	20
Air Cooled Engine	21
Controls - Recoil Starter	21
Recoil Starter.....	21
Decompression Lever	21
Indicators and Controls – Electric Starter.....	21
Indicators.....	22
Controls	22
Inlet Air Heater	23
Engine Speed Controls	23
Before You Operate	25
Diesel Fuel	29
Diesel Fuel Specifications	29
Filling the Fuel Tank	30
Engine Oil.....	32
Engine Oil Specifications.....	32
Engine Oil Viscosity.....	33
Checking Engine Oil.....	33
Adding Engine Oil.....	33
Engine Oil Capacity (Typical)	34
Daily Checks	34
Visual Checks.....	34
Check Diesel Fuel and Engine Oil.....	35
Check Engine Speed Control (First Time Only)	35
Check Indicators.....	35
Engine Operation	37
Starting the Engine.....	44
Recoil Start.....	44
Electric Start	46
Check the Engine During Operation.....	49
Adjust Engine Speed.....	50

Shutting Down the Engine	52
Preparing To Stop Engine	52
Set Engine Speed Control to STOP	52
Electric Start Models.....	53
After The Engine Stops	53
Periodic Maintenance	55
Precautions	66
The Importance of Periodic Maintenance.....	66
Performing Periodic Maintenance	66
The Importance of Daily Checks	66
Keep a Log of Engine Hours and Daily Checks	66
Yanmar Replacement Parts	66
Tools Required	66
Ask Your Authorized Yanmar Industrial Engine Dealer or Distributor For Help.....	66
Required EPA / ARB Maintenance - USA Only.....	67
EPA / ARB Installation Requirements - USA Only	67
Tightening Fasteners.....	67
Standard Torque Chart.....	67
Periodic Maintenance Schedule	68
Periodic Maintenance Procedures	70
Daily, Before Operation	70
Daily, After Operation	75
After Initial 50 Hours of Operation	77
Every 50 Hours of Operation	79
Every 200 Hours of Operation	80
Every 400 Hours of Operation	84
Every 1000 Hours of Operation	85
Every 1500 Hours of Operation	85
Every 2000 Hours of Operation	86
Troubleshooting	87
Troubleshooting Chart.....	87
Troubleshooting Information.....	89
Long Term Storage	91
Before You Place the Engine in Long Term Storage	91
Returning the Engine to Service.....	93
Specifications	95
General.....	95
Description of Model Number	95
Engine Speed Specifications.....	95
Engine General Specifications	96
Principal Engine Specifications	97

TABLE OF CONTENTS

Engine Specifications 97

SAFETY

SAFETY STATEMENTS

Yanmar is concerned for your safety and your machine's condition. Safety statements are one of the primary ways to call your attention to the potential hazards associated with Yanmar LV Series engine operation. Follow the precautions listed throughout the manual before operation, during operation and during periodic maintenance procedures for your safety, the safety of others and to protect the performance of your engine. Keep the labels from becoming dirty or torn and replace them if they are lost or damaged. Also, if you need to replace a part that has a label attached to it, make sure you order the new part and label at the same time.



This safety alert symbol appears with most safety statements. It means attention, become alert, your safety is involved! Please read and abide by the message that follows the safety alert symbol.

DANGER

Danger (the word “DANGER” is in white letters with a red rectangle behind it) – indicates an imminently hazardous situation which, if not avoided, will result in death or serious injury. Danger is limited to the most extreme situations.

0000001en

WARNING

Warning (the word “WARNING” is in black letters with an orange rectangle behind it) – indicates a potentially hazardous situation which, if not avoided, could result in death or serious injury.

0000001en

CAUTION

Caution (the word “CAUTION” is in black letters with a yellow rectangle behind it) – indicates a potentially hazardous situation which, if not avoided, may result in minor or moderate injury.

0000001en

CAUTION

Caution *without the safety alert symbol* indicates a potentially hazardous situation that can cause damage to the machine, personal property and / or the environment or cause the machine to operate improperly.

0000001en

SAFETY PRECAUTIONS

Before You Operate

CAUTION
 <p>NEVER permit anyone to operate the engine or driven machine without proper training.</p> <ul style="list-style-type: none">• Read and understand this Operation Manual before you operate the machine to ensure that you follow safe operating practices and maintenance procedures.• Machine safety signs and labels are additional reminders for safe operating and maintenance techniques.• See your authorized Yanmar industrial engine dealer or distributor for additional training. <p style="text-align: right;">000002en</p>

During Operation and Maintenance

! DANGER

<p>EXPLOSION HAZARD!</p> <ul style="list-style-type: none">• Keep the area around the battery well ventilated. While the engine is running or the battery is charging, hydrogen gas is produced which can be easily ignited.• Keep sparks, open flame and any other form of ignition away.• Failure to comply will result in death or serious injury. <p style="text-align: right;">000003en</p>

⚠ DANGER**FIRE AND EXPLOSION HAZARD!**

- Diesel fuel is extremely flammable and explosive under certain conditions.
- When you remove any fuel system component to perform maintenance (such as changing the fuel filter) place an approved container under the opening to catch the fuel.
- NEVER use a shop rag to catch the fuel. Vapors from the rag are extremely flammable and explosive.
- Wipe up any spills immediately.
- Wear eye protection. The fuel system is under pressure and fuel could spray out when you remove any fuel system component.
- Failure to comply will result in death or serious injury.

000009en

⚠ DANGER**FIRE AND EXPLOSION HAZARD!**

- Only use the key switch to start the engine.
- NEVER jump start the engine. Sparks caused by jumping the battery to the starter terminals may cause a fire or explosion.
- Failure to comply will result in death or serious injury.

000004en

⚠ DANGER**FIRE AND EXPLOSION HAZARD!**

- Diesel fuel is extremely flammable and explosive under certain conditions.
- NEVER use diesel fuel as a cleaning agent.
- Failure to comply will result in death or serious injury.

000012en

⚠ DANGER**FIRE AND EXPLOSION HAZARD!**

- Diesel fuel is extremely flammable and explosive under certain conditions.
- NEVER remove the fuel cap with the engine running.
- Failure to comply will result in death or serious injury.

000011en

⚠ DANGER



FIRE AND EXPLOSION HAZARD!

- Diesel fuel is extremely flammable and explosive under certain conditions.
- Only fill the fuel tank with diesel fuel. Filling the fuel tank with gasoline may result in a fire.
- NEVER refuel with the engine running.
- Wipe up all spills immediately.
- Keep sparks, open flames or any other form of ignition (match, cigarette, static electric source) away when fueling / refueling.
- NEVER overfill the fuel tank.
- Fill the fuel tank and store fuel in a well-ventilated area only.
- Failure to comply will result in death or serious injury.

000005en

⚠ DANGER



FIRE AND EXPLOSION HAZARD!

- Diesel fuel is extremely flammable and explosive under certain conditions.
- Be sure to place the diesel fuel container on the ground when transferring the diesel fuel from the pump to the container. Hold the hose nozzle firmly against the side of the container while filling it. This prevents static electricity build-up which could cause sparks and ignite fuel vapors.
- NEVER place diesel fuel or other flammable material such as oil, hay or dried grass close to the engine during engine operation or shortly after shut down.
- Failure to comply will result in death or serious injury.

0000014en

⚠ DANGER**FIRE AND EXPLOSION HAZARD!**

- Diesel fuel is extremely flammable and explosive under certain conditions.
- Before you operate the engine, check for fuel leaks. Replace rubberized fuel hoses every two years or every 2000 hours of engine operation, whichever comes first, even if the engine has been out of service. Rubberized fuel lines tend to dry out and become brittle after two years or 2000 hours of engine operation, whichever comes first.
- Failure to comply will result in death or serious injury.

0000015en

⚠ DANGER**CRUSH HAZARD!**

- When you need to transport an engine for repair, have a helper assist you to attach it to a hoist and load it on a truck.
- NEVER stand under a hoisted engine. If the hoist mechanism fails, the engine will fall on you, causing serious injury or death.
- Failure to comply will result in death or serious injury.

000008en

⚠ DANGER**EXPLOSION HAZARD!**

- NEVER check the remaining battery charge by shorting out the terminals. This will result in a spark and may cause an explosion or fire. Use a hydrometer to check the remaining battery charge.
- If the electrolyte is frozen, slowly warm the battery before you recharge it.
- Failure to comply will result in death or serious injury.

000007en

⚠ WARNING



SEVER HAZARD!

- Keep hands and other body parts away from moving / rotating parts such as the cooling fan / flywheel.
- Wear tight fitting clothing and keep your hair short or tie it back while the engine is running.
- Remove all jewelry before you operate or service the machine.
- NEVER start the engine in gear. Sudden movement of the engine and / or machine could cause death or serious personal injury.
- NEVER operate the engine without the guards in place.
- Before you start the engine make sure that all bystanders are clear of the area.
- Keep children and pets away while the engine is operating.
- Check before starting the engine that any tools or shop rags used during maintenance have been removed from the area.
- Failure to comply could result in death or serious injury.

000002enLV

⚠ WARNING



EXHAUST HAZARD!

- NEVER operate the engine in an enclosed area such as a garage, tunnel, underground room, manhole or ship's hold without proper ventilation.
- NEVER block windows, vents, or other means of ventilation if the engine is operating in an enclosed area. All internal combustion engines create carbon monoxide gas during operation. Accumulation of this gas within an enclosure could cause illness or even death.
- Make sure that all connections are tightened to specifications after repair is made to the exhaust system.
- Failure to comply could result in death or serious injury.

000003en

⚠ WARNING



ALCOHOL AND DRUG HAZARD!

- NEVER operate the engine while you are under the influence of alcohol or drugs.
- NEVER operate the engine when you are feeling ill.
- Failure to comply could result in death or serious injury.

000004en

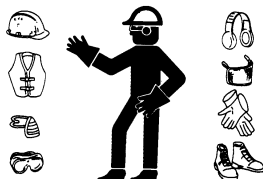
! WARNING**EXPOSURE HAZARD!**

- Wear personal protective equipment such as gloves, work shoes, eye and hearing protection as required by the task at hand.
- NEVER wear jewelry, unbuttoned cuffs, ties or loose fitting clothing when you are working near moving / rotating parts such as the cooling fan, flywheel or PTO shaft.
- ALWAYS tie long hair back when you are working near moving / rotating parts such as a cooling fan, flywheel, or PTO shaft.
- NEVER operate the engine while wearing a headset to listen to music or radio because it will be difficult to hear the warning signals.
- Failure to comply could result in death or serious injury.

0000005en

! WARNING**BURN HAZARD!**

- Batteries contain sulfuric acid. NEVER allow battery fluid to come in contact with clothing, skin or eyes. Severe burns could result. ALWAYS wear safety goggles and protective clothing when servicing the battery. If contact with the skin and / or eyes should occur, flush with a large amount of water and obtain prompt medical treatment.
- Failure to comply could result in death or serious injury.

0000007en

! WARNING**HIGH PRESSURE HAZARD!**

- Avoid skin contact with the high pressure diesel fuel spray caused by a fuel system leak such as a broken fuel injection line. High pressure fuel can penetrate your skin and result in serious injury. If you are exposed to high pressure fuel spray, obtain prompt medical treatment.
- NEVER check for a fuel leak with your hands. ALWAYS use a piece of wood or cardboard. Have your authorized Yanmar industrial engine dealer or distributor repair the damage.
- Failure to comply could result in death or serious injury.

0000008en

⚠ WARNING



SHOCK HAZARD!

- Turn off the battery switch (if equipped) or disconnect the negative battery cable before servicing the electrical system.
- Check the electrical harnesses for cracks, abrasions, and damaged or corroded connectors. **ALWAYS** keep the connectors and terminals clean.
- Failure to comply could result in death or serious injury.

000009en

⚠ WARNING



SEVER HAZARD!

- Stop the engine before you begin to service it.
- **NEVER** leave the key in the key switch when you are servicing the engine. Someone may accidentally start the engine and not realize you are servicing it. This could result in a serious injury.
- If you must service the engine while it is operating, remove all jewelry, tie long hair back, and keep your hands, other body parts and clothing away from moving / rotating parts.
- Failure to comply could result in death or serious injury.

000010en

⚠ WARNING



BURN HAZARD!

- If you must drain the engine oil while it is still hot, stay clear of the hot engine oil to avoid being scalded. Make sure you wear eye protection.
- Failure to comply could result in death or serious injury.

000011en

⚠ WARNING



BURN HAZARD!

- Keep your hands and other body parts away from hot engine surfaces such as the muffler, exhaust pipe, turbocharger (if equipped) and engine block during operation and shortly after you shut the engine down. These surfaces are extremely hot while the engine is operating and could seriously burn you.
- Failure to comply could result in death or serious injury.

000015en

CAUTION**FLYING OBJECT HAZARD!**

- **ALWAYS** wear eye protection when servicing the engine and when using compressed air or high-pressure water. Dust, flying debris, compressed air, pressurized water or steam may injure your eyes.
- Failure to comply may result in minor or moderate injury.

000003en

CAUTION

- Only use diesel fuels recommended by Yanmar for the best engine performance, to prevent engine damage and to comply with EPA / ARB warranty requirements.
- Only use clean diesel fuel.
- **NEVER** remove inlet fuel screen from the filler port. If removed, dirt and debris could get into the fuel system causing it to clog.

000004enLV

CAUTION

NEVER attempt to adjust the low or high idle speed limit screw. This may impair the safety and performance of the machine and shorten its life. If adjustment is ever required, contact your authorized Yanmar industrial engine dealer or distributor.

0000045en

CAUTION

If any problem is noted during the visual check, the necessary corrective action should be taken before you operate the engine.

0000021en

CAUTION

NEVER hold the key in the **START** position for longer than 15 seconds or the starter motor will overheat.

000007en

CAUTION

The illustrations and descriptions of optional equipment in this manual, such as the operator's console, are for a typical engine installation. Refer to the documentation supplied by the optional equipment manufacturer for specific operation and maintenance instructions.

0000018en

CAUTION

If any indicator illuminates during engine operation stop the engine immediately. Determine the cause and repair the problem before you continue to operate the engine.

0000029en

CAUTION

Observe the following environmental operating conditions to maintain engine performance and avoid premature engine wear:

- Avoid operating in extremely dusty conditions.
- Avoid operating in the presence of chemical gases or fumes.
- Avoid operating in a corrosive atmosphere such as salt water spray.
- NEVER install the engine in a floodplain unless proper precautions are taken to avoid being subject to a flood.
- NEVER expose the engine to the rain.

000003en

CAUTION

NEVER allow the recoil handle to snap back against the engine. Return the handle to the starting position gently to prevent damage to the starter.

000006en

CAUTION

Observe the following environmental operating conditions to maintain engine performance and avoid premature engine wear:

- NEVER run the engine if the ambient temperature is above +104°F (+40°C) or below +14°F (-10°C)
 - ◆ If the ambient temperature exceeds +104°F (+40°C) the engine may overheat and cause the engine oil to break down.
 - ◆ If the ambient temperature falls below +14°F (-10°C) rubber components such as gaskets and seals will harden causing premature engine wear and damage.
 - ◆ Contact your authorized Yanmar industrial engine dealer or distributor if the engine will be operated in either temperature extreme.
- Contact your authorized Yanmar industrial engine dealer or distributor if you need to operate the engine at high altitudes. At high altitudes the engine will lose power, run rough, and produce exhaust gases that exceed the design specifications.

0000065enLV

CAUTION

- Only use the engine oil specified. Other engine oils may affect warranty coverage, cause internal engine components to seize, or shorten engine life.
- Prevent dirt and debris from contaminating the engine oil. Carefully clean the oil cap / dipstick and the surrounding area before you remove the cap.
- NEVER mix different types of engine oil. This may adversely affect the lubricating properties of the engine oil.
- NEVER overfill. Overfilling may result in white exhaust smoke, engine overspeed or internal damage.

000005en

CAUTION

NEVER use an engine starting aid such as ether. Engine damage will result.

000009en

CAUTION

Make sure the engine is installed on a level surface. If a continuously running engine is installed at an angle greater than 20° (in any direction) or if an engine runs for short periods of time (less than 3 minutes) at an angle greater than 25° in any direction, engine oil may enter the combustion chamber causing excessive engine speed and generate white smoke. This may cause serious engine damage.

000010enTNE

CAUTION

- NEVER overfill the engine with engine oil.
- ALWAYS keep the oil level between the upper and lower lines on the oil cap / dipstick.

000015en

CAUTION

For maximum engine life, Yanmar recommends that when shutting the engine down, you allow the engine to idle, without load, for 5 minutes. This will allow the engine components that operate at high temperatures, such as the turbocharger (if equipped) and exhaust system, to cool slightly before the engine itself is shut down.

000008en

CAUTION

New Engine Break In:

- On the initial engine start-up, allow the engine to idle for approximately 15 minutes while you check for proper engine oil pressure, diesel fuel leaks, engine oil leaks, coolant leaks, and for proper operation of the indicators and / or gauges.
- During the first hour of operation, vary the engine speed and the load on the engine. Short periods of maximum engine speed and load are desirable. Avoid prolonged operation at minimum or maximum engine speeds and loads for the next 4 to 5 hours.
- During the break-in period, carefully observe the engine oil pressure and engine temperature.
- During the break-in period, check the engine oil and coolant levels frequently.

000011en

CAUTION

NEVER engage the starter motor while the engine is running. This may damage the starter motor pinion and / or ring gear.

0000012en

CAUTION

- **NEVER** attempt to modify the engine's design or safety features such as defeating the engine speed limit control or the fuel injection quantity control.
- Failure to comply may impair the engine's safety and performance characteristics and shorten the engine's life. Any alterations to this engine may affect the warranty coverage of your engine. *See Yanmar Limited Warranty on page vii.*

0000044enLVOM

CAUTION

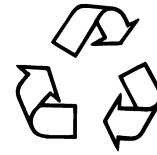

Be environmentally responsible. Follow these procedures for hazardous waste disposal. Failure to follow these procedures may seriously harm the environment.

- Follow the guidelines of the EPA or other governmental agency for the proper disposal of hazardous materials such as engine oil, diesel fuel and engine coolant. Consult the local authorities or reclamation facility.
- **NEVER** dispose of hazardous materials irresponsibly by dumping them into a sewer, on the ground or into ground water or waterways.

0000013en

CAUTION

Protect the air cleaner, turbocharger (if equipped) and electric components from damage when you use steam or use high-pressure water to clean the engine.

0000014en

CAUTION

The tightening torque in the *Standard Torque Chart (page 67)* should be carefully observed.

- Apply 60% torque to bolts that are not listed.
- Apply 80% torque when tightened to aluminum alloy.

0000023enLVOM

CAUTION

Establish a periodic maintenance plan according to the engine application and make sure you perform the required periodic maintenance at intervals indicated. Failure to follow these guidelines will impair the engine's safety and performance characteristics, shorten the engine's life and may affect the warranty coverage on your engine. *See Yanmar Limited Warranty on page vii.*

Consult your authorized Yanmar industrial engine dealer or distributor for assistance when checking items marked with a ●.

0000024enLVOM

CAUTION

It is important to perform daily checks. *See Daily Checks on page 34.*

Periodic maintenance prevents unexpected downtime, reduces the number of accidents due to poor machine performance and helps extend the life of the engine.

0000060enLVOM

CAUTION

- When the engine is operated in dusty conditions, clean the air cleaner element more frequently.
- NEVER operate the engine with the air cleaner or element(s) removed. This may cause foreign material to enter the engine and damage it.

0000026en

CAUTION

The maximum air intake restriction shall be:

- L48V: 0.10 psi (0.69 kPa; 70 mm Aq) or less
- L70V: 0.20 psi (1.37 kPa; 140 mm Aq) or less
- L100V: 0.21 psi (1.47 kPa; 150 mm Aq) or less.

Clean or replace the air cleaner element if the air intake restriction exceeds the above mentioned value.

0000046enLV

CAUTION

Tips while starting engine with recoil starter (*See Start The Engine on page 47.*):

- Pulling out the recoil starter handle too hard or fast will damage the equipment.
- ALWAYS pull recoil starter handle all the way out or the engine will not start.
- NEVER allow the recoil starter handle to snap back against the engine. Return the handle to the starting position gently to prevent damage to the recoil starter.

0000068enLVOM

CAUTION

If the engine continues to run after you position the engine speed control to the STOP position, turn the fuel cock to the CLOSED position.

0000069en

This Page Intentionally Left Blank

PRODUCT OVERVIEW

YANMAR LV SERIES ENGINE FEATURES AND APPLICATIONS

To achieve the highest performing miniaturized and light-weight diesel engines, Yanmar Co., Ltd. developed the LV series single cylinder, air-cooled, diesel engine using the most advanced single cylinder technologies.

Yanmar has incorporated Exhaust Gas Recirculation (EGR) technology to meet the stringent exhaust emissions demands required by the Environmental Protection Agency (EPA - US Federal) and the California Air Resources Board (ARB, California). In addition, the pump / line / nozzle direct-injection system has been optimized to reduce emissions.

Yanmar LV Series engines are designed to supply power to a wide variety of driven machines including:

- Pumps
- Power Generation
- Construction
- Agriculture

We are sure that you will agree these features provide excellent value in an industrial diesel engine.

These engines are designed to deliver power to driven machines by means of a “direct coupled drive” or “belt drive.” In direct coupled drive engine applications, the engine’s flywheel housing or end plate is coupled directly to the driven machine. In belt drive engine applications, a belt drive is used to power the driven machine.

The engine is designed for a wide range of applications. Options are available to customize the application.

Since designing the application and installing the engine require special knowledge and skill, always consult your authorized Yanmar industrial engine dealer or distributor for these services. They will help you:

- Select optional equipment. Optional equipment should be selected to match the work conditions and environment.
- Maximize engine performance with a minimum amount of downtime and safety related incidents by carefully matching the characteristics of the engine with the driven machine.
- Plan for safe fuel piping, exhaust piping, electrical wiring, ventilation and accurate engine installation.
- Design your applications so they meet requirements of the local authorities.

PRODUCT OVERVIEW

COMPONENT IDENTIFICATION

Figure 1 shows where major engine components are located.

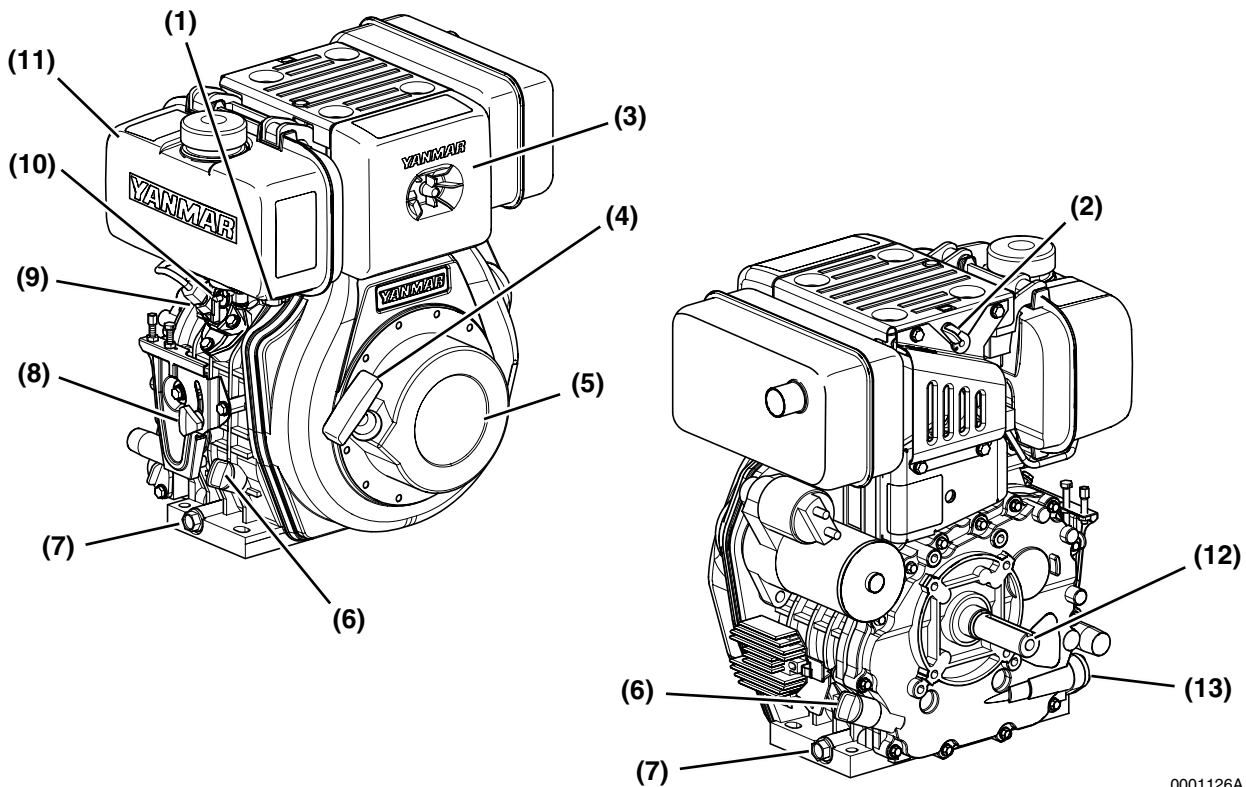

Figure 1

- | | |
|--------------------------|-------------------------------|
| 1. Fuel Drain Plug | 8. Engine Speed Control Lever |
| 2. Decompression Lever | 9. Fuel Injection Pump |
| 3. Air Cleaner | 10. Fuel Cock |
| 4. Recoil Starter Handle | 11. Fuel Tank |
| 5. Recoil Starter | 12. PTO Shaft |
| 6. Oil Cap / Dipstick | 13. Oil Filter |
| 7. Oil Drain Plug | |

Note: L48V standard engines are not equipped with covers. L70V and L100V engines are represented in this manual.

LOCATION OF LABELS

Figure 2 shows the location of regulatory and safety labels on Yanmar LV Series engines.

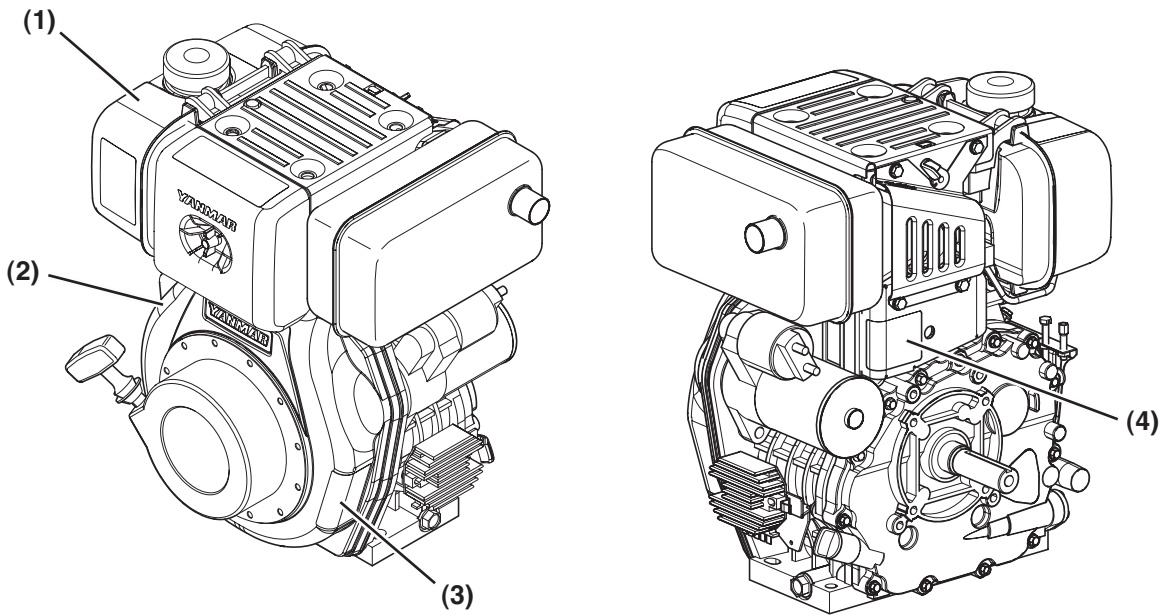

0001126C

Figure 2

The typical location of the emission control information label for LV Series engines is on the top of the fuel tank or on the flywheel cover (Figure 2, (1)).

- L48V, L70V and L100V (Figure 2, (1)) if engine is equipped with a Yanmar fuel Tank.
- L48V (Figure 2, (2)) if engine is not equipped with a Yanmar fuel Tank.
- L70V and L100V (Figure 2, (3)) if engine is not equipped with a Yanmar fuel Tank.

Typical location of the engine nameplate is shown (Figure 2, (4)).

Engine Nameplate (Typical)



0001585

PRODUCT OVERVIEW

EPA / ARB EMISSION CONTROL REGULATIONS - USA ONLY

Yanmar LV Series engines meet Environmental Protection Agency (EPA) (U. S. Federal) emission control standards as well as the California Air Resources Board (ARB, California) regulations. Only engines that conform to ARB regulations can be sold in the State of California.

Refer to the specific EPA / ARB installation (Page 67) and maintenance (Page 67) in the *Periodic Maintenance* section of this manual. Also refer to the *Yanmar Co., Ltd. Limited Emission Control* on page x.

EMISSION CONTROL LABELS - USA ONLY

Since emission control regulations are being issued on a global basis, it is necessary to identify which regulations a particular engine complies with. We have listed several different types of labels you might find on your engine.

EPA / ARB Labels

IMPORTANT ENGINE INFORMATION	
THIS ENGINE CONFORMS TO [] MODEL YEAR U. S. EPA REGULATIONS.	
THIS ENGINE IS CERTIFIED TO OPERATE ON *Type 2-D* FUEL.	
ENGINE FAMILY : []	DISPLACEMENT : [] LITERS
ENGINE MODEL : []	EMISSION CONTROL SYSTEM : []
FUEL RATE : [] MM ³ /STROKE @ [] kW/[] RPM	
REFER TO OWNER'S MANUAL FOR MAINTENANCE SPECIFICATIONS AND ADJUSTMENTS.	
 YANMAR CO., LTD.	

For L100V (G2 mode engine)

IMPORTANT ENGINE INFORMATION	
THIS ENGINE CONFORMS TO [] M. Y. CALIFORNIA AND U. S. EPA REGULATIONS FOR OFF-ROAD C. I. ENGINES.	
THIS ENGINE IS CERTIFIED TO OPERATE ON *Type 2-D* FUEL.	
ENGINE FAMILY : []	DISPLACEMENT : [] LITERS
ENGINE MODEL : []	EMISSION CONTROL SYSTEM : []
FUEL RATE : [] MM ³ /STROKE @ [] kW/[] RPM	
[]	
REFER TO OWNER'S MANUAL FOR MAINTENANCE SPECIFICATIONS AND ADJUSTMENTS.	
 YANMAR CO., LTD.	

For L70V & L100V (C1 mode engine)

IMPORTANT ENGINE INFORMATION	
THIS ENGINE CONFORMS TO [] M. Y. CALIFORNIA AND U. S. EPA REGULATIONS FOR OFF-ROAD C. I. ENGINES.	
THIS ENGINE IS CERTIFIED TO OPERATE ON *Type 2-D* FUEL.	
ENGINE FAMILY : []	DISPLACEMENT : [] LITERS
ENGINE MODEL : []	EMISSION CONTROL SYSTEM : EM
FUEL RATE : [] MM ³ /STROKE @ [] kW/[] RPM	
FEL NOx+NMHC : 10.5g/kWh PM : 1.0g/kWh	
REFER TO OWNER'S MANUAL FOR MAINTENANCE SPECIFICATIONS AND ADJUSTMENTS.	
 YANMAR CO., LTD.	

For L48V (A.B.T. program)

The 97/68/EC Directive Certified Engines

The engines described in this manual have been certified by the 97/68/EC Directive.

To identify the engines that meet this certification, the 97/68/EC emission control label is affixed on the engines.

IMPORTANT ENGINE INFORMATION	
THIS ENGINE CONFORMS TO 97/68/EC DIRECTIVE	
ENGINE FAMILY :	[]
ENGINE MODEL :	[]
APPROVAL NUMBER :	[]
 YANMAR CO.,LTD.	

(97/68/EC)

ENGINE FAMILY

The EPA / ARB labels and the 97/68/EC label all have an *Engine Family* field. The following is an explanation of the *Engine Family* designation:

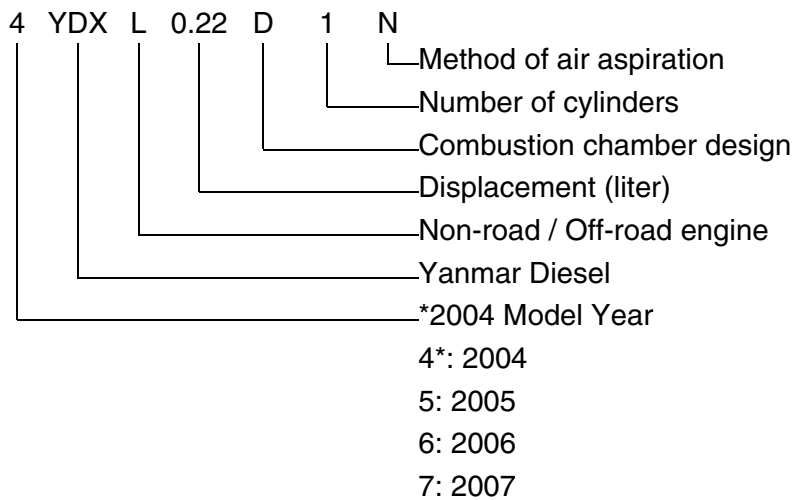

FUNCTION OF MAJOR ENGINE COMPONENTS

Components	Functions
Air Cleaner	The air cleaner prevents airborne contaminants from entering the engine. Periodic replacement of the air cleaner filter element is necessary. See the <i>Periodic Maintenance Schedule on page 68</i> for the replacement frequency.
Dynamo (Optional)	If the engine is equipped with the electric starting option, a dynamo is located between engine body and flywheel. The dynamo supplies electricity to the engine systems and charges the battery while the engine is running.
Electric Fuel Pump (Optional)	The electric fuel pump (if equipped) makes sure there is a constant supply of diesel fuel to the fuel injection pump. The electric fuel pump is electro-magnetic and runs on 12 VDC.
Engine Oil Filter	The engine oil filter removes contaminants and sediments from the engine oil. Periodic cleaning of the oil filter is necessary. See the <i>Periodic Maintenance Schedule on page 68</i> for the frequency of cleaning.
Fuel Filters	Two fuel filters are provided to remove contaminants and sediments from the diesel fuel. The inlet fuel screen is located inside the fuel tank filler port. Since it uses a mesh construction, it can be cleaned. The outlet fuel filter is a replaceable cartridge that is located at the outlet of the fuel tank. Periodic cleaning / replacement is required. See <i>Periodic Maintenance Schedule on page 68</i> .
Fuel Tank	The fuel tank is a reservoir that holds diesel fuel. When fuel leaves the fuel tank it goes to the fuel injection pump. Since fuel is used to keep fuel system components cool and lubricated, more fuel than is necessary for combustion enters the fuel system. Any fuel that is not used for combustion is returned to the fuel tank. The fuel tank is a required engine component.
Oil Cap / Dipstick (Engine Oil)	The engine oil cap / dipstick combines the oil cap and dipstick in one assembly. The dipstick part of the assembly is used to determine the amount of engine oil in the crankcase.
Side Filler Ports (Engine Oil)	You can fill the crankcase with engine oil from either side of the engine depending upon which one is most convenient.
Starter Motor (Optional)	If the engine is equipped with the electric starting option, the starter motor is powered by the battery. When you turn the key switch in the operator's console to the START position, the starter motor engages with the ring gear installed on the flywheel and starts the flywheel in motion.

AIR COOLED ENGINE

The LV engine is air-cooled by means of a cooling fan. The cooling system consists of a fan attached to the flywheel.

CONTROLS - RECOIL STARTER

The LV Series engines are equipped with a recoil or electric starter. This section explains the controls available with the recoil starter.

Recoil Starter

A recoil starter allows you to manually start an engine by pulling on the recoil starter handle (Figure 3, (1)). When you pull on the handle you set the flywheel and crankshaft in motion. The recoil starter is spring loaded so the handle and attached cable automatically return to the recoil starter assembly.

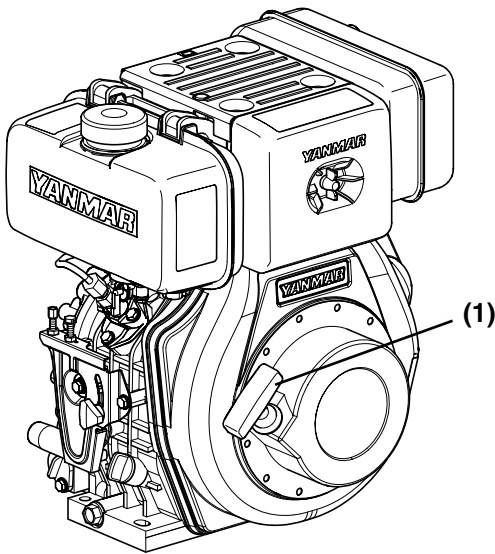

0001126B

Figure 3

Decompression Lever

The decompression lever (Figure 4, (1)) helps you start the engine by reducing the effort needed to pull the recoil starter handle. The decompression lever will automatically return to the original position when the engine starts. Some LV model engines have an automatic, internal compression release mechanism and do not have the external compression release lever. Refer to the specific instructions for your driven machine.

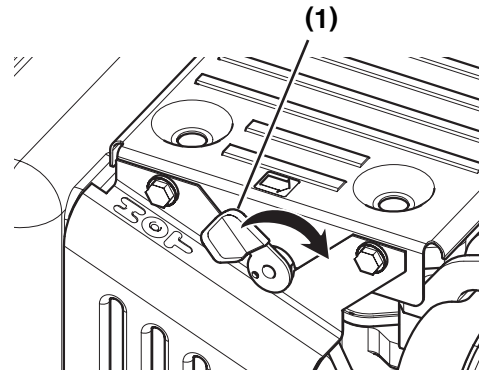

0001347A

Figure 4

INDICATORS AND CONTROLS – ELECTRIC STARTER

If an LV series engine is ordered with an electric starter it will include a key switch and may also have indicators to monitor engine functions.

CAUTION

The illustrations and descriptions of optional equipment in this manual, such as the operator's console, are for a typical engine installation. Refer to the documentation supplied by the optional equipment manufacturer for specific operation and maintenance instructions.

0000018en

Indicators

Battery - (Figure 5, (1)) - Your driven machine may have a battery indicator that comes on if there is a problem in the charging system. This indicator does not indicate whether the battery is discharged. See *Troubleshooting Chart on page 87*.

Heat - If your engine has an inlet air heater, it may have a heat indicator that lights when the inlet air heater is activated. Follow the instructions provided by the driven machine manufacturer for the operation of this indicator.

Controls

Key Switch

If your engine is equipped with electric start it may have a three position key switch - OFF, ON, and START. See **Figure 5** for an illustration of a typical key switch.

CAUTION

For maximum engine life, Yanmar recommends that when shutting the engine down, you allow the engine to idle, without load, for 5 minutes. This will allow the engine components that operate at high temperatures, such as the turbocharger (if equipped) and exhaust system, to cool slightly before the engine itself is shut down.

000008en

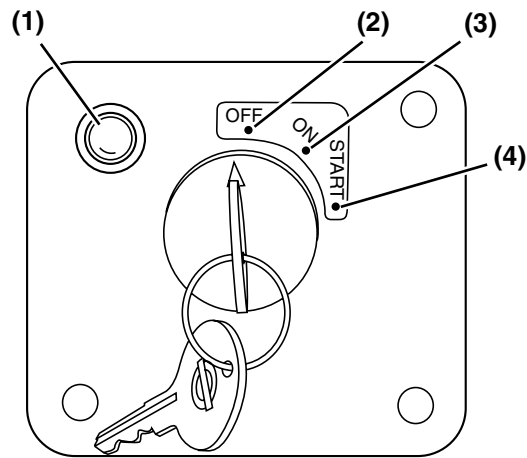

Figure 5

OFF (key straight up and down) (Figure 5, (2)) - When you turn the key to this position the engine shuts down. Electric current to the battery indicator and other electric devices is shut off. You can insert and remove the key in this position.

ON (Figure 5, (3)) - This is the position the key will be in when the engine is running. When the engine is not running, use this position to energize the optional devices such as indicators or electric fuel pump.

CAUTION

Only hold the key in the START position for 15 seconds or the starter motor will overheat.

0000020en

START (Figure 5, (4)) - Turn the key to this position to start the engine. As soon as the engine starts, release the key and it will automatically return to the ON position. Some key switches may be equipped with a feature that prevents you from turning the key to the START position while the engine is running. In these configurations, you cannot turn the key to the START position without first returning the key to the OFF position.

Inlet Air Heater

Some engines may be equipped with an inlet air heater. Heated inlet air helps the engine to start easier in cold weather. During the engine starting sequence the inlet air heater is activated for several seconds. If the engine is equipped with an air inlet heater timer, after the heat indicator goes out, the engine can be started.

Engine Speed Controls

CAUTION

NEVER attempt to adjust the low or high idle speed limit screw. This may impair the safety and performance of the machine and shorten its life. If adjustment is ever required, contact your authorized Yanmar industrial engine dealer or distributor.

0000045en

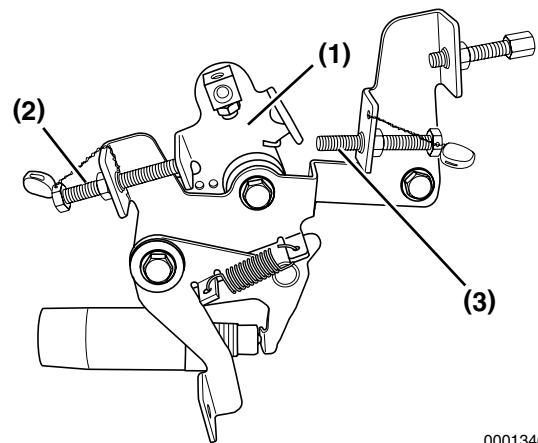

0001346A

Figure 6

Several types of engine speed controls are used in LV engine applications. This illustration shows a typical example. Refer to the operating instructions for the driven machine.

The speed control lever (**Figure 6, (1)**) controls the engine speed. The lever could be linked to the engine speed control device.

The low idle speed limit screw (**Figure 6, (2)**) sets engine speed while it is idling.

The high idle speed limit screw (**Figure 6, (3)**) restricts the maximum engine speed when the engine is operated without a load.

This Page Intentionally Left Blank

BEFORE YOU OPERATE

This section of the *Operation Manual* describes the diesel fuel and engine oil specifications and how to replenish them. It also describes the daily engine checkout.

CAUTION



NEVER permit anyone to operate the engine or driven machine without proper training.

- Read and understand this Operation Manual before you operate the machine to ensure that you follow safe operating practices and maintenance procedures.
- Machine safety signs and labels are additional reminders for safe operating and maintenance techniques.
- See your authorized Yanmar industrial engine dealer or distributor for additional training.

000002en

DANGER



FIRE AND EXPLOSION HAZARD!

- Diesel fuel is extremely flammable and explosive under certain conditions.
- Only fill the fuel tank with diesel fuel. Filling the fuel tank with gasoline may result in a fire.
- NEVER refuel with the engine running.
- Wipe up all spills immediately.
- Keep sparks, open flames or any other form of ignition (match, cigarette, static electric source) away when fueling / refueling.
- NEVER overfill the fuel tank.
- Fill the fuel tank and store fuel in a well-ventilated area only.
- Failure to comply will result in death or serious injury.

000005en

⚠ DANGER



FIRE AND EXPLOSION HAZARD!

- Diesel fuel is extremely flammable and explosive under certain conditions.
- Be sure to place the diesel fuel container on the ground when transferring the diesel fuel from the pump to the container. Hold the hose nozzle firmly against the side of the container while filling it. This prevents static electricity build-up which could cause sparks and ignite fuel vapors.
- NEVER place diesel fuel or other flammable material such as oil, hay or dried grass close to the engine during engine operation or shortly after shut down.
- Failure to comply will result in death or serious injury.

0000014en

⚠ DANGER



FIRE AND EXPLOSION HAZARD!

- Diesel fuel is extremely flammable and explosive under certain conditions.
- Before you operate the engine, check for fuel leaks. Replace rubberized fuel hoses every two years or every 2000 hours of engine operation, whichever comes first, even if the engine has been out of service. Rubberized fuel lines tend to dry out and become brittle after two years or 2000 hours of engine operation, whichever comes first.
- Failure to comply will result in death or serious injury.

0000015en

! WARNING



HIGH PRESSURE HAZARD!

- Avoid skin contact with the high pressure diesel fuel spray caused by a fuel system leak such as a broken fuel injection line. High pressure fuel can penetrate your skin and result in serious injury. If you are exposed to high pressure fuel spray, obtain prompt medical treatment.
- NEVER check for a fuel leak with your hands. ALWAYS use a piece of wood or cardboard. Have your authorized Yanmar industrial engine dealer or distributor repair the damage.
- Failure to comply could result in death or serious injury.

000008en

! WARNING



BURN HAZARD!

- Keep your hands and other body parts away from hot engine surfaces such as the muffler, exhaust pipe, turbocharger (if equipped) and engine block during operation and shortly after you shut the engine down. These surfaces are extremely hot while the engine is operating and could seriously burn you.
- Failure to comply could result in death or serious injury.

0000015en

! WARNING



BURN HAZARD!

- If you must drain the engine oil while it is still hot, stay clear of the hot engine oil to avoid being scalded. Make sure you wear eye protection.
- Failure to comply could result in death or serious injury.

0000011en

CAUTION

- Only use diesel fuels recommended by Yanmar for the best engine performance, to prevent engine damage and to comply with EPA / ARB warranty requirements.
- Only use clean diesel fuel.
- NEVER remove inlet fuel screen from the filler port. If removed, dirt and debris could get into the fuel system causing it to clog.

000004enLV

CAUTION

- **Only use the engine oil specified. Other engine oils may affect warranty coverage, cause internal engine components to seize, or shorten engine life.**
- **Prevent dirt and debris from contaminating the engine oil. Carefully clean the oil cap / dipstick and the surrounding area before you remove the cap.**
- **NEVER mix different types of engine oil. This may adversely affect the lubricating properties of the engine oil.**
- **NEVER overfill. Overfilling may result in white exhaust smoke, engine overspeed or internal damage.**

000005en

CAUTION

If any problem is noted during the visual check, the necessary corrective action should be taken before you operate the engine.

0000021en

DIESEL FUEL

Diesel Fuel Specifications

Diesel fuel should comply with the following specifications. The table lists several worldwide specifications for diesel fuels.

Diesel Fuel Specification	Location
No. 2-D, No. 1-D, ASTM D975-94	USA
EN590:96	European Union
ISO 8217 DMX	International
BS 2869-A1 or A2	United Kingdom
JIS K2204 Grade No.2	Japan
KSM-2610	Korea
GB252	China

Additional Technical Fuel Requirements

- The fuel cetane number should be equal to 45 or higher.
- The sulfur content must not exceed 0.5% by volume. Less than 0.05% is preferred.
- Bio-Diesel fuels. *See Bio-Diesel Fuels on page 29.*
- NEVER mix kerosene, used engine oil, or residual fuels with the diesel fuel.
- Water and sediment in the fuel should not exceed 0.05% by volume.
- Keep the fuel tank and fuel-handling equipment clean at all times.
- Poor quality fuel can reduce engine performance and / or cause engine damage.
- Fuel additives are not recommended. Some fuel additives may cause poor engine performance. Consult your Yanmar representative for more information.
- Ash content not to exceed 0.01% by volume.
- Carbon residue content not to exceed 0.35% by volume. Less than 0.1% is preferred.

- Total aromatics content should not exceed 35% by volume. Less than 30% is preferred.
- PAH (polycyclic aromatic hydrocarbons) content should be below 10% by volume.
- Metal content of Na, Mg, Si, and Al should be equal to or lower than 1 mass ppm. (Test analysis method JPI-5S-44-95)
- Lubricity: Wear mark of WS1.4 should be Max. 0.018 in (460 µm) at HFRR test.

Bio-Diesel Fuels

In Europe and in the United States, as well as some other countries, non-mineral oil based fuel resources such as RME (Rapeseed Methyl Ester) and SOME (Soybean Methyl Ester), collectively known as FAME (Fatty Acid Methyl Esters), are being used as extenders for mineral oil derived diesel fuels.

Yanmar approves the use of bio-diesel fuels that do not exceed a blend of 5% (by volume) of FAME with 95% (by volume) of approved mineral oil derived diesel fuel. Such bio-diesel fuels are known in the marketplace as B5 diesel fuels.

These B5 diesel fuels must meet certain requirements.

1. The bio-fuels must meet the minimum specifications for the country in which they are used.
 - In Europe, bio-diesel fuels must comply with the European Standard EN14214.
 - In the United States, bio-diesel fuels must comply with the American Standard ASTM D-6751.
2. Bio-fuels should be purchased only from recognized and authorized diesel fuel suppliers.

Precautions and concerns regarding the use of bio-fuels:

1. Free methanol in FAME may result in corrosion of aluminum and zinc FIE components.
2. Free water in FAME may result in plugging of fuel filters and increased bacterial growth.

BEFORE YOU OPERATE

3. High viscosity at low temperatures may result in fuel delivery problems, injection pump seizures, and poor injection nozzle spray atomization.
4. FAME may have adverse effects on some elastomers (seal materials) and may result in fuel leakage and dilution of the engine lubricating oil.
5. Even bio-diesel fuels that comply with a suitable standard as delivered, will require additional care and attention to maintain the quality of the fuel in the equipment or other fuel tanks. It is important to maintain a supply of clean, fresh fuel. Regular flushing of the fuel system, and/or fuel storage containers, may be necessary.
6. The use of bio-diesel fuels that do not comply with the standards as agreed to by the diesel engine manufacturers and the diesel fuel injection equipment manufacturers, or bio-diesel fuels that have degraded as per the precautions and concerns above, may affect the warranty coverage of your engine. See *Yanmar Limited Warranty on page vii*.

Filling the Fuel Tank

! DANGER



FIRE AND EXPLOSION HAZARD!

- **Diesel fuel is extremely flammable and explosive under certain conditions.**
- **Only fill the fuel tank with diesel fuel. Filling the fuel tank with gasoline may result in a fire.**
- **NEVER refuel with the engine running.**
- **Wipe up all spills immediately.**
- **Keep sparks, open flames or any other form of ignition (match, cigarette, static electric source) away when fueling / refueling.**
- **NEVER overfill the fuel tank.**
- **Fill the fuel tank and store fuel in a well-ventilated area only.**
- **Failure to comply will result in death or serious injury.**

000005en

⚠ DANGER**FIRE AND EXPLOSION HAZARD!**

- Diesel fuel is extremely flammable and explosive under certain conditions.
- Be sure to place the diesel fuel container on the ground when transferring the diesel fuel from the pump to the container. Hold the hose nozzle firmly against the side of the container while filling it. This prevents static electricity build-up which could cause sparks and ignite fuel vapors.
- NEVER place diesel fuel or other flammable material such as oil, hay or dried grass close to the engine during engine operation or shortly after shut down.
- Failure to comply will result in death or serious injury.

0000014en

⚠ DANGER**FIRE AND EXPLOSION HAZARD!**

- Diesel fuel is extremely flammable and explosive under certain conditions.
- Before you operate the engine, check for fuel leaks. Replace rubberized fuel hoses every two years or every 2000 hours of engine operation, whichever comes first, even if the engine has been out of service. Rubberized fuel lines tend to dry out and become brittle after two years or 2000 hours of engine operation, whichever comes first.
- Failure to comply will result in death or serious injury.

0000015en

CAUTION

- Only use diesel fuels recommended by Yanmar for the best engine performance, to prevent engine damage and to comply with EPA / ARB warranty requirements.
- Only use clean diesel fuel.
- NEVER remove inlet fuel screen from the filler port. If removed, dirt and debris could get into the fuel system causing it to clog.

000004enLV

Note that a typical fuel tank is shown. The fuel tank on your engine may be different. ***Also note that the inlet fuel screen is shown removed from the fuel tank for clarity. ALWAYS make sure the inlet fuel screen remains inside of the fuel tank while fueling!***

BEFORE YOU OPERATE

1. Clean the area around the fuel cap (**Figure 1, (1)**).
2. Remove the fuel cap (**Figure 1, (1)**) from the fuel tank (**Figure 1, (3)**).
3. Stop fueling when the fuel is at the same level as the red ring (**Figure 1, (4)**) at the bottom of the inlet fuel screen. NEVER overfill the fuel tank.
4. Replace the fuel cap (**Figure 1, (1)**) and hand tighten. Over-tightening the fuel cap will damage it.

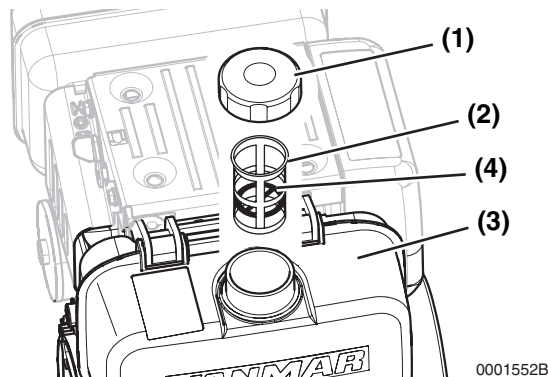

Figure 1

ENGINE OIL

CAUTION

- Only use the engine oil specified. Other engine oils may affect warranty coverage, cause internal engine components to seize, or shorten engine life.
- Prevent dirt and debris from contaminating the engine oil. Carefully clean the oil cap / dipstick and the surrounding area before you remove the cap.
- NEVER mix different types of engine oil. This may adversely affect the lubricating properties of the engine oil.
- NEVER overfill. Overfilling may result in white exhaust smoke, engine overspeed or internal damage.

000005en

Engine Oil Specifications

Use an engine oil that meets or exceeds the following guidelines and classifications:

Service Categories

- API Service Categories CD or higher
- ACEA Service Categories E-3, E-4, and E-5
- JASO Service Category DH-1

Definitions

- API Classification (American Petroleum Institute)
- ACEA Classification (Association des Constructeurs Européens d'Automobiles)
- JASO (Japanese Automobile Standards Organization)

Notes:

1. Be sure the engine oil, engine oil storage containers, and engine oil filling equipment are free of sediments and water.

2. Change the engine oil after the first 50 hours of operation and then at every 200 hours thereafter.
3. Select the oil viscosity based on the ambient temperature where the engine is being operated. See SAE Service Grade Viscosity Chart (**Figure 2**).
4. Yanmar does not recommend the use of engine oil “additives.”

Additional Technical Engine oil Requirements:

The engine oil must be changed when the Total Base Number (TBN) has been reduced to 2.0. TBN (mgKOH/g) test method; JIS K-201-5.2-2 (HCl), ASTM D4739 (HCl)

Engine Oil Viscosity

Select the appropriate engine oil viscosity based on the ambient temperature and use the SAE Service Grade Viscosity Chart in **Figure 2**.

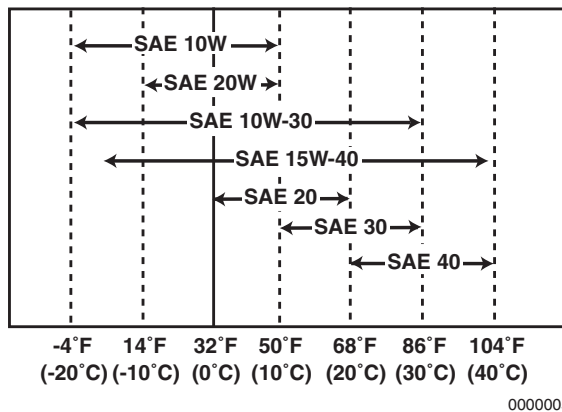

Figure 2

Checking Engine Oil

1. Make sure engine is level.
2. Remove oil cap / dipstick (**Figure 3, (1)**) from either location and wipe with clean cloth.
3. Fully reinsert oil cap / dipstick **but do not screw in**.
4. Remove oil cap / dipstick. The oil level should be between upper (**Figure 3, (2)**) and lower (**Figure 3, (3)**) lines on the oil cap / dipstick.

5. Fully reinsert oil cap / dipstick (**Figure 3, (1)**) and hand tighten. Over-tightening the oil cap / dipstick will damage it.

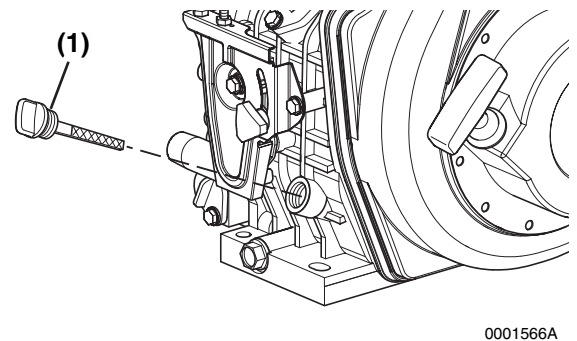
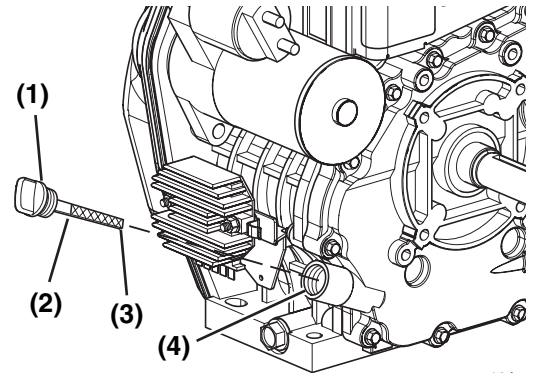

Figure 3

Adding Engine Oil

1. Make sure engine is level.
2. Remove oil cap / dipstick (**Figure 3, (1)**).
3. Add indicated amount of engine oil at either one of the engine oil filler ports (**Figure 3, (4)**).
4. Wait one minute and check oil level.
5. Add more oil if necessary.
6. Fully reinsert oil cap / dipstick (**Figure 3, (1)**) and hand tighten. Over-tightening the oil cap / dipstick will damage it.

BEFORE YOU OPERATE

Engine Oil Capacity (Typical)

The following are the engine oil capacities for various Yanmar LV Series engines.

Engine Model	Dipstick Upper Limit/ Lower Limit
L48V	0.85 / 0.58 qt (0.80 / 0.55 L)
L70V	1.11 / 0.69 qt (1.05 / 0.65 L)
L100V	1.7 / 1.06 qt (1.6 / 1.0 L)

Note: Oil capacity will vary depending upon which optional oil pan is used. Refer to the operation manual provided by the driven machine manufacturer for the actual engine oil capacity of your machine.

DAILY CHECKS

Before you begin any job, make sure the Yanmar LV Series engine is in good operating condition. Make sure you check the following items before you start your shift and have any repairs completed before you start work.

WARNING



HIGH PRESSURE HAZARD!

- **Avoid skin contact with the high pressure diesel fuel spray caused by a fuel system leak such as a broken fuel injection line. High pressure fuel can penetrate your skin and result in serious injury. If you are exposed to high pressure fuel spray, obtain prompt medical treatment.**
- **NEVER check for a fuel leak with your hands. ALWAYS use a piece of wood or cardboard. Have your authorized Yanmar industrial engine dealer or distributor repair the damage.**
- **Failure to comply could result in death or serious injury.**

0000008en

Visual Checks

1. Check for engine oil leaks.
2. Check for fuel leaks.
3. Check for damaged or missing parts.
4. Check for loose, missing, or damaged fasteners.
5. Check the electrical harnesses for cracks, abrasions, and damaged or corroded connectors.
6. Check hoses for cracks, abrasions, and damaged, loose or corroded clamps.

CAUTION
<p>If any problem is noted during the visual check, the necessary corrective action should be taken before you operate the engine.</p> <p style="text-align: right; font-size: small;">0000021en</p>

Check Diesel Fuel and Engine Oil

Follow the procedures in *Diesel Fuel on page 29* and *Engine Oil on page 32* to check these levels.

Check Engine Speed Control (First Time Only)

1. Check the engine speed control for smooth operation and lubricate or clean as necessary.

2. Check engine speed control for proper adjustments.

Check Indicators

If your engine has an electric starter, check the battery indicator. Also check any other indicators supplied by the driven machine manufacturer.

Battery - Stays On until the engine is running and the dynamo is supplying charging current. This indicator does not indicate whether the battery is discharged.

Here is a summary of how these indicators function. The table shows what happens when you turn the key in a certain direction (e.g., OFF to ON).

Indicator	OFF to ON	START to ON
Battery	ON	OFF (Stays On until dynamo is supplying charging current. Remains On if there is a problem in the charging system. This indicator does not indicate whether the battery is discharged.)

This Page Intentionally Left Blank

ENGINE OPERATION

This section of the *Operation Manual* describes the procedures for starting the engine, checking engine performance during operation, and shutting the engine down.

CAUTION



NEVER permit anyone to operate the engine or driven machine without proper training.

- Read and understand this Operation Manual before you operate the machine to ensure that you follow safe operating practices and maintenance procedures.
- Machine safety signs and labels are additional reminders for safe operating and maintenance techniques.
- See your authorized Yanmar industrial engine dealer or distributor for additional training.

000002en

DANGER



EXPLOSION HAZARD!

- Keep the area around the battery well ventilated. While the engine is running or the battery is charging, hydrogen gas is produced which can be easily ignited.
- Keep sparks, open flame and any other form of ignition away.
- Failure to comply will result in death or serious injury.

000003en

DANGER



FIRE AND EXPLOSION HAZARD!

- Only use the key switch to start the engine.
- NEVER jump start the engine. Sparks caused by jumping the battery to the starter terminals may cause a fire or explosion.
- Failure to comply will result in death or serious injury.

000004en

DANGER



FIRE AND EXPLOSION HAZARD!

- Diesel fuel is extremely flammable and explosive under certain conditions.
- NEVER remove the fuel cap with the engine running.
- Failure to comply will result in death or serious injury.

0000011en

DANGER



FIRE AND EXPLOSION HAZARD!

- Diesel fuel is extremely flammable and explosive under certain conditions.
- Only fill the fuel tank with diesel fuel. Filling the fuel tank with gasoline may result in a fire.
- NEVER refuel with the engine running.
- Wipe up all spills immediately.
- Keep sparks, open flames or any other form of ignition (match, cigarette, static electric source) away when fueling / refueling.
- NEVER overfill the fuel tank.
- Fill the fuel tank and store fuel in a well-ventilated area only.
- Failure to comply will result in death or serious injury.

0000005en

⚠ DANGER



FIRE AND EXPLOSION HAZARD!

- Diesel fuel is extremely flammable and explosive under certain conditions.
- Be sure to place the diesel fuel container on the ground when transferring the diesel fuel from the pump to the container. Hold the hose nozzle firmly against the side of the container while filling it. This prevents static electricity build-up which could cause sparks and ignite fuel vapors.
- NEVER place diesel fuel or other flammable material such as oil, hay or dried grass close to the engine during engine operation or shortly after shut down.
- Failure to comply will result in death or serious injury.

0000014en

⚠ DANGER



FIRE AND EXPLOSION HAZARD!

- Diesel fuel is extremely flammable and explosive under certain conditions.
- Before you operate the engine, check for fuel leaks. Replace rubberized fuel hoses every two years or every 2000 hours of engine operation, whichever comes first, even if the engine has been out of service. Rubberized fuel lines tend to dry out and become brittle after two years or 2000 hours of engine operation, whichever comes first.
- Failure to comply will result in death or serious injury.

0000015en

⚠ WARNING



BURN HAZARD!

- Keep your hands and other body parts away from hot engine surfaces such as the muffler, exhaust pipe, turbocharger (if equipped) and engine block during operation and shortly after you shut the engine down. These surfaces are extremely hot while the engine is operating and could seriously burn you.
- Failure to comply could result in death or serious injury.

0000015en

WARNING



SEVER HAZARD!

- Keep hands and other body parts away from moving / rotating parts such as the cooling fan / flywheel.
- Wear tight fitting clothing and keep your hair short or tie it back while the engine is running.
- Remove all jewelry before you operate or service the machine.
- NEVER start the engine in gear. Sudden movement of the engine and / or machine could cause death or serious personal injury.
- NEVER operate the engine without the guards in place.
- Before you start the engine make sure that all bystanders are clear of the area.
- Keep children and pets away while the engine is operating.
- Check before starting the engine that any tools or shop rags used during maintenance have been removed from the area.
- Failure to comply could result in death or serious injury.

000002enLV

WARNING



EXHAUST HAZARD!

- NEVER operate the engine in an enclosed area such as a garage, tunnel, underground room, manhole or ship's hold without proper ventilation.
- NEVER block windows, vents, or other means of ventilation if the engine is operating in an enclosed area. All internal combustion engines create carbon monoxide gas during operation. Accumulation of this gas within an enclosure could cause illness or even death.
- Make sure that all connections are tightened to specifications after repair is made to the exhaust system.
- Failure to comply could result in death or serious injury.

000003en

WARNING



ALCOHOL AND DRUG HAZARD!

- NEVER operate the engine while you are under the influence of alcohol or drugs.
- NEVER operate the engine when you are feeling ill.
- Failure to comply could result in death or serious injury.

000004en

⚠ WARNING

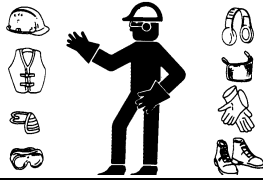

EXPOSURE HAZARD!

- Wear personal protective equipment such as gloves, work shoes, eye and hearing protection as required by the task at hand.
- NEVER wear jewelry, unbuttoned cuffs, ties or loose fitting clothing when you are working near moving / rotating parts such as the cooling fan, flywheel or PTO shaft.
- ALWAYS tie long hair back when you are working near moving / rotating parts such as a cooling fan, flywheel, or PTO shaft.
- NEVER operate the engine while wearing a headset to listen to music or radio because it will be difficult to hear the warning signals.
- Failure to comply could result in death or serious injury.

0000005en

CAUTION

NEVER use an engine starting aid such as ether. Engine damage will result.

0000009en

CAUTION

For maximum engine life, Yanmar recommends that when shutting the engine down, you allow the engine to idle, without load, for 5 minutes. This will allow the engine components that operate at high temperatures, such as the turbocharger (if equipped) and exhaust system, to cool slightly before the engine itself is shut down.

0000008en

CAUTION

Make sure the engine is installed on a level surface. If a continuously running engine is installed at an angle greater than 20° (in any direction) or if an engine runs for short periods of time (less than 3 minutes) at an angle greater than 25° in any direction, engine oil may enter the combustion chamber causing excessive engine speed and generate white smoke. This may cause serious engine damage.

0000010enTNE

CAUTION

New Engine Break In:

- On the initial engine start-up, allow the engine to idle for approximately 15 minutes while you check for proper engine oil pressure, diesel fuel leaks, engine oil leaks, coolant leaks, and for proper operation of the indicators and / or gauges.
- During the first hour of operation, vary the engine speed and the load on the engine. Short periods of maximum engine speed and load are desirable. Avoid prolonged operation at minimum or maximum engine speeds and loads for the next 4 to 5 hours.
- During the break-in period, carefully observe the engine oil pressure and engine temperature.
- During the break-in period, check the engine oil and coolant levels frequently.

000011en

CAUTION

Observe the following environmental operating conditions to maintain engine performance and avoid premature engine wear:

- Avoid operating in extremely dusty conditions.
- Avoid operating in the presence of chemical gases or fumes.
- Avoid operating in a corrosive atmosphere such as salt water spray.
- NEVER install the engine in a floodplain unless proper precautions are taken to avoid being subject to a flood.
- NEVER expose the engine to the rain.

000003en

CAUTION

NEVER hold the key in the **START** position for longer than 15 seconds or the starter motor will overheat.

000007en

CAUTION

Observe the following environmental operating conditions to maintain engine performance and avoid premature engine wear:

- **NEVER** run the engine if the ambient temperature is above +104°F (+40°C) or below +14°F (-10°C)
 - ◆ If the ambient temperature exceeds +104°F (+40°C) the engine may overheat and cause the engine oil to break down.
 - ◆ If the ambient temperature falls below +14°F (-10°C) rubber components such as gaskets and seals will harden causing premature engine wear and damage.
 - ◆ Contact your authorized Yanmar industrial engine dealer or distributor if the engine will be operated in either temperature extreme.
- Contact your authorized Yanmar industrial engine dealer or distributor if you need to operate the engine at high altitudes. At high altitudes the engine will lose power, run rough, and produce exhaust gases that exceed the design specifications.

000065enLV

CAUTION

NEVER engage the starter motor while the engine is running. This may damage the starter motor pinion and / or ring gear.

000012en

STARTING THE ENGINE

Recoil Start

CAUTION

NEVER use an engine starting aid such as ether. Engine damage will result.

000009en

Use the following procedure to start the engine.

Daily Checks

1. Make sure you follow the procedures stated in *Daily Checks on page 34*.
2. Make sure the fuel cock is in the ON position (**Figure 1, (1)**).

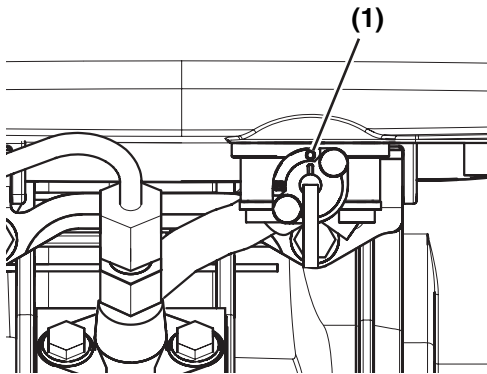

0001124A

Figure 1

Set Engine Speed Control to START

Several types of engine speed controls are used in LV engine applications. The following procedures are for three typical applications. Refer to the operating instructions for the driven machine.

1. If your engine speed control is similar to **Figure 2** slide the engine speed control lever (**Figure 2, (1)**) to the RUN position (**Figure 2, (2)**).

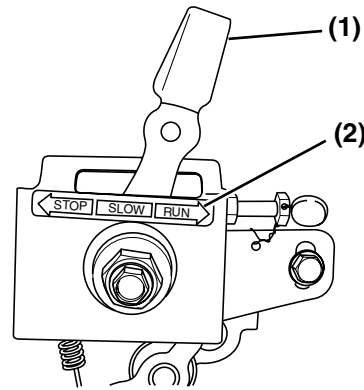

0001354A

Figure 2

2. If your engine speed control is similar to **Figure 3** slide the engine speed control lever (**Figure 3, (1)**) to the RUN position (**Figure 3, (2)**).

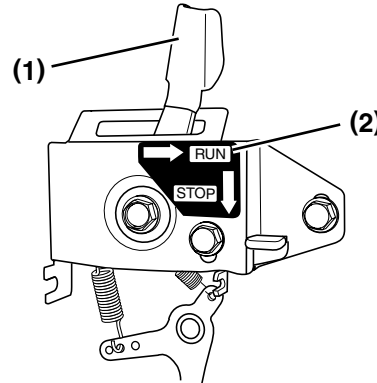

0001355A

Figure 3

3. If your engine speed control is similar to **Figure 4**:
 - (a) Turn the engine speed control knob (**Figure 4, (1)**) to the left (**Figure 4, (2)**).
 - (b) Slide the engine speed control knob to the START position (**Figure 4, (3)**).
 - (c) Turn the engine speed control knob to the right (**Figure 4, (4)**) to tighten it.

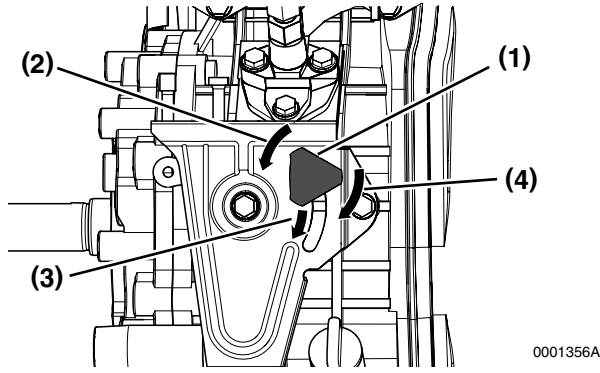

Figure 4

0001356A

Start The Engine

CAUTION

Tips while starting engine with recoil starter (See *Start The Engine* on page 47.):

- Pulling out the recoil starter handle too hard or fast will damage the equipment.
- **ALWAYS** pull recoil starter handle all the way out or the engine will not start.
- **NEVER** allow the recoil starter handle to snap back against the engine. Return the handle to the starting position gently to prevent damage to the recoil starter.

0000068enLVOM

CAUTION

NEVER use an engine starting aid such as ether. Engine damage will result.

0000009en

4. Push the decompression lever (**Figure 8, (1)**) down and release it. The decompression lever will automatically return to the original position when the engine starts. Some LV model engines have an automatic, internal compression release mechanism and do not have the external compression release lever. Refer to the specific instructions for your driven machine.
5. Grasp the recoil starter handle (**Figure, (1)**).
6. Pull the handle all the way out with a strong and even motion. Use two hands if necessary.
7. Slowly return the recoil starter handle to the initial position.
8. If the engine does not start, repeat the *Start The Engine* procedure from Step 1.

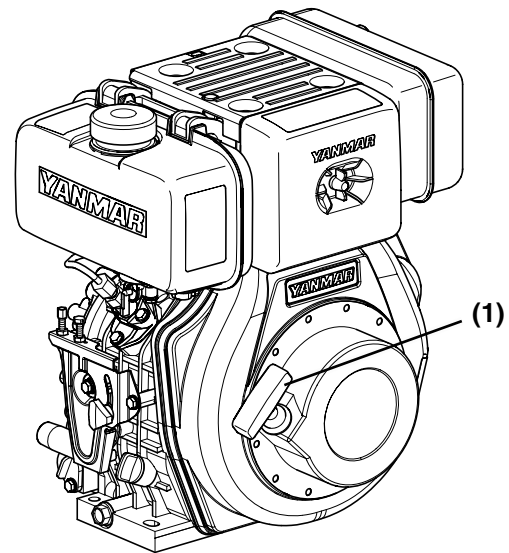

Figure 5

0001126B

1. Grasp the recoil starter handle (**Figure, (1)**).
2. Pull the handle out slowly until you feel strong resistance.
3. Slowly return the recoil starter handle to the initial position.

ENGINE OPERATION

In Cold Weather - L48V Only

If you have trouble pulling the recoil handle on an L48V engine in cold weather follow this procedure:

1. Remove the oil plug (**Figure 6, (1)**).
2. Add 2 cc of engine oil to the oil port (**Figure 7, (1)**).

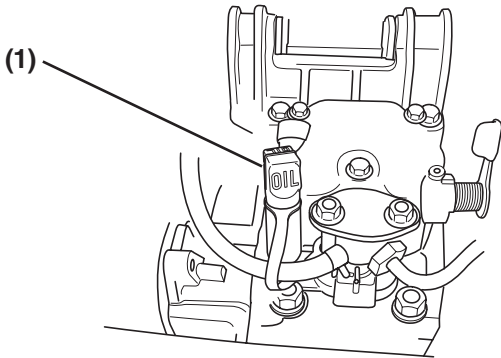

0001581

Figure 6

3. Reinsert the oil plug (**Figure 6, (1)**).

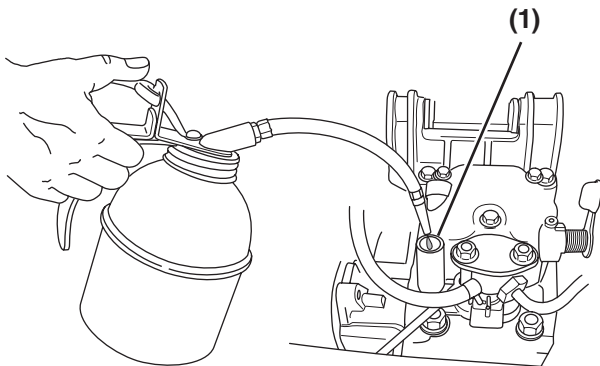

0001580

Figure 7

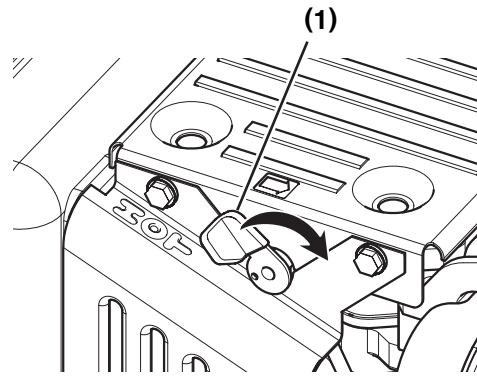

0001347A

Figure 8

Electric Start

CAUTION

NEVER use an engine starting aid such as ether. Engine damage will result.

000009en

Use the following procedure to start the engine.

Daily Checks

1. Make sure you follow the procedures stated in *Daily Checks on page 34*.
2. Make sure the fuel cock is in the ON position (**Figure 9, (1)**).

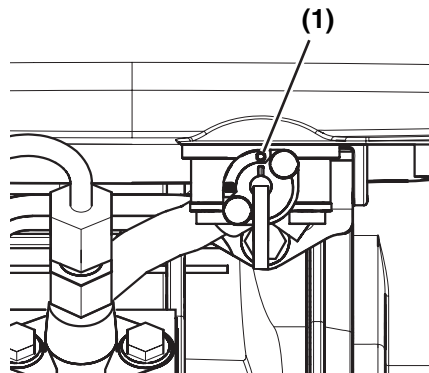

0001124A

Figure 9

Set Engine Speed Control to START

Several types of engine speed controls are used in LV engine applications. The following procedures are for three typical applications. Refer to the operating instructions for the driven machine.

1. If your engine speed control is similar to **Figure 10** slide the engine speed control lever (**Figure 10, (1)**) to the RUN position (**Figure 10, (2)**).

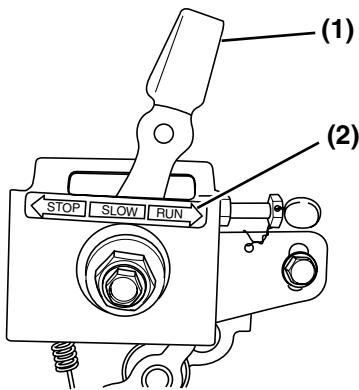

0001354A

Figure 10

2. If your engine speed control is similar to **Figure 11** slide the engine speed control lever (**Figure 11, (1)**) to the RUN position or (**Figure 11, (2)**).

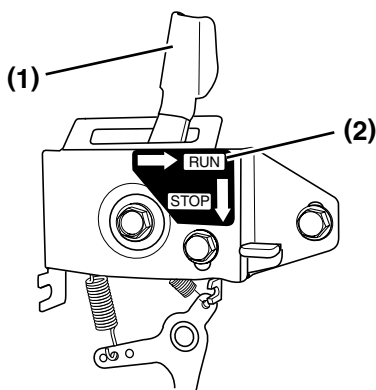

0001355A

Figure 11

3. If your engine speed control is similar to **Figure 12**:
 - (a) Turn the engine speed control knob (**Figure 12, (1)**) to the left (**Figure 12, (2)**).
 - (b) Slide the engine speed control knob to the START position (**Figure 12, (3)**).
 - (c) Turn the engine speed control knob to the right (**Figure 12, (4)**) to tighten it.

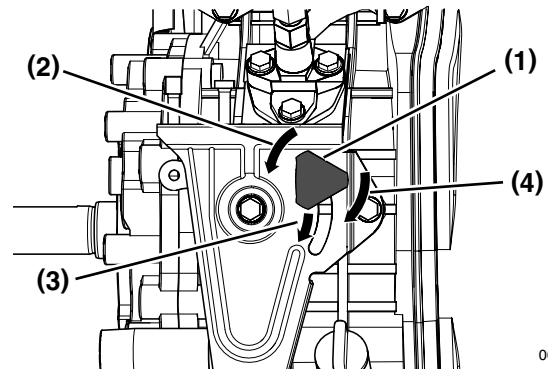

0001356A

Figure 12

Start The Engine

CAUTION

NEVER use an engine starting aid such as ether. Engine damage will result.

000009en

Use the following procedure to start the engine.

1. Insert the key into the key switch.

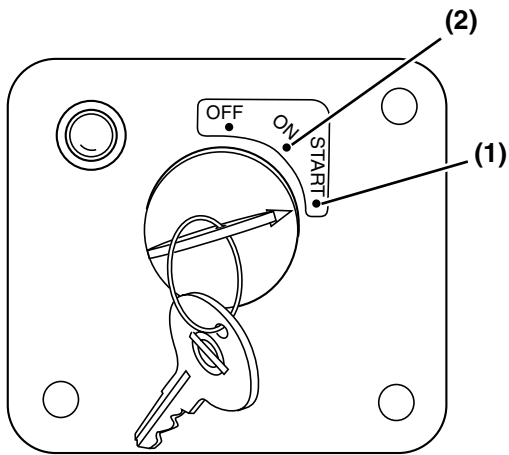

0001549C

Figure 13

2. Turn the key clockwise to the START position (**Figure 13, (1)**). Release the key as soon as the engine starts. It will return to the ON position (**Figure 13, (2)**).

3. If the engine fails to start:
 - (a) Wait until the engine comes to a complete stop before you attempt to start it again. Engaging the starter while the engine is still rotating will result in damage to the starter motor and flywheel.
 - (b) Wait at least 30 seconds before you attempt to start the engine again. This pause will allow the battery voltage to recover to prevent damage to the starter motor due to the low battery voltage.

CHECK THE ENGINE DURING OPERATION

CAUTION

Make sure the engine is installed on a level surface. If a continuously running engine is installed at an angle greater than 20° (in any direction) or if an engine runs for short periods of time (less than 3 minutes) at an angle greater than 25° in any direction, engine oil may enter the combustion chamber causing excessive engine speed and generate white smoke. This may cause serious engine damage.

0000010enTNE

CAUTION

New Engine Break In:

- On the initial engine start-up, allow the engine to idle for approximately 15 minutes while you check for proper engine oil pressure, diesel fuel leaks, engine oil leaks, coolant leaks, and for proper operation of the indicators and / or gauges.
- During the first hour of operation, vary the engine speed and the load on the engine. Short periods of maximum engine speed and load are desirable. Avoid prolonged operation at minimum or maximum engine speeds and loads for the next 4 to 5 hours.
- During the break-in period, carefully observe the engine oil pressure and engine temperature.
- During the break-in period, check the engine oil and coolant levels frequently.

0000011en

1. After the engine has reached operating temperature, all of the indicators (if equipped) should be Off. If any of the indicators are On, shut down the engine and have the necessary repairs performed.

⚠ WARNING



HIGH PRESSURE HAZARD!

- Avoid skin contact with the high pressure diesel fuel spray caused by a fuel system leak such as a broken fuel injection line. High pressure fuel can penetrate your skin and result in serious injury. If you are exposed to high pressure fuel spray, obtain prompt medical treatment.
- NEVER check for a fuel leak with your hands. ALWAYS use a piece of wood or cardboard. Have your authorized Yanmar industrial engine dealer or distributor repair the damage.
- Failure to comply could result in death or serious injury.

0000008en

2. Check for any fuel or engine oil leaks. If any leaks are found shut down the engine and have the necessary repairs performed.
3. Check for abnormal sounds or vibration. In some applications the engine and its mounting may start to resonate and cause unusual vibrations at certain engine speeds. Avoid running the engine at these speeds. If the abnormal sounds or vibration cannot be resolved, shut down the engine and have the necessary repairs performed.

4. Check for white or black smoke from the exhaust system. A small amount of white exhaust smoke is normal on start-up of a cold engine. Black exhaust smoke could mean the engine is overloaded or being over-fueled. If either of these conditions persists, contact your authorized Yanmar industrial engine dealer or distributor.
5. Check the fuel level during operation. If the fuel level runs low, stop the engine and refuel.

ADJUST ENGINE SPEED

CAUTION

New Engine Break In:

- On the initial engine start-up, allow the engine to idle for approximately 15 minutes while you check for proper engine oil pressure, diesel fuel leaks, engine oil leaks, coolant leaks, and for proper operation of the indicators and / or gauges.
- During the first hour of operation, vary the engine speed and the load on the engine. Short periods of maximum engine speed and load are desirable. Avoid prolonged operation at minimum or maximum engine speeds and loads for the next 4 to 5 hours.
- During the break-in period, carefully observe the engine oil pressure and engine temperature.
- During the break-in period, check the engine oil and coolant levels frequently.

0000011en

Use the engine speed control to adjust the engine speed for the task that will be performed.

Several types of engine speed controls are used in LV engine applications. The following procedures are for three typical applications. Refer to the operating instructions for the driven machine.

1. If your engine speed control is similar to **Figure 14** slide the engine speed control lever (**Figure 14, (1)**) in the direction shown to adjust the engine speed.

Note: This is a friction adjustment. If the speed control will not maintain a given speed, tightening the nut will increase the friction on the speed control lever.

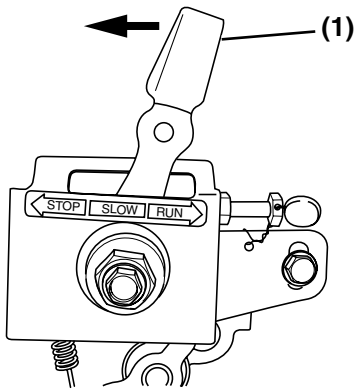

0001354B

Figure 14

2. If your engine speed control is similar to **Figure 15** slide the engine speed control lever (**Figure 15, (1)**) in the direction shown to adjust the engine speed.

Note: This type of speed control, typically used on a generator set, has only one speed setting. When you move the lever to the right, it clicks into the RUN position. The speed control lever is spring-loaded so when you push down on the STOP button, the speed control lever moves back to the shut-off position. There is no idle position or intermediate speeds.

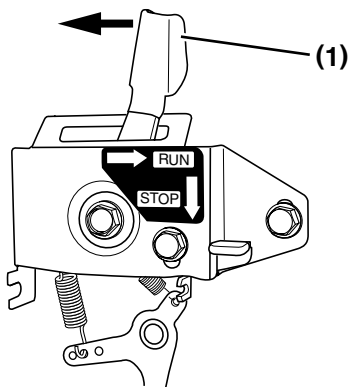

0001355B

Figure 15

3. If your engine speed control is similar to **Figure 16**:
 - (a) Turn the engine speed control knob (**Figure 16, (1)**) to the left (**Figure 16, (2)**).
 - (b) Slide the engine speed control knob in the direction shown to adjust the engine speed.
 - (c) Turn the engine speed control knob to the right (**Figure 16, (3)**) to tighten it.

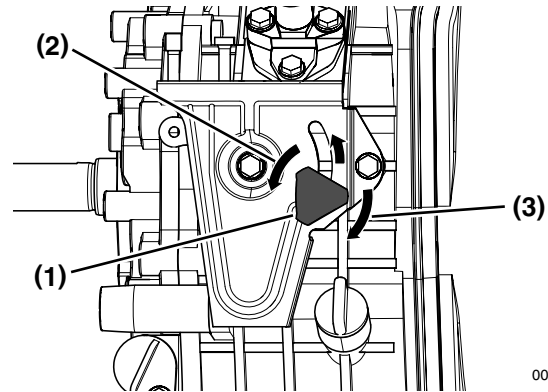

0001363C

Figure 16

SHUTTING DOWN THE ENGINE

CAUTION

For maximum engine life, Yanmar recommends that when shutting the engine down, you allow the engine to idle, without load, for 5 minutes. This will allow the engine components that operate at high temperatures, such as the turbocharger (if equipped) and exhaust system, to cool slightly before the engine itself is shut down.

000008en

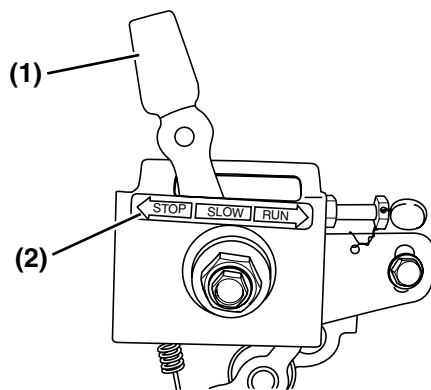

0001361A

Figure 17

Preparing To Stop Engine

Follow these steps to shut down the engine:

1. Disengage the PTO.
2. Set the engine speed control to its lowest setting.
3. Run the engine at low idle speed or run without load for at least five minutes before you shut it down.

Set Engine Speed Control to STOP

CAUTION

If the engine continues to run after you position the engine speed control to the STOP position, turn the fuel cock to the CLOSED position.

0000069en

Several types of engine speed controls are used in LV engine applications. The following procedures are for three typical applications. Refer to the operating instructions for the driven machine.

1. If your engine speed control is similar to **Figure 17** slide the engine speed control lever (**Figure 17, (1)**) to the STOP position (**Figure 17, (2)**).

2. If your engine speed control is similar to **Figure 18** press the STOP button (**Figure 18, (1)**) and the engine speed control lever (**Figure 18, (2)**) will automatically return to the STOP position.

Note: The speed control lever is spring-loaded so when you push down on the STOP button, the speed control lever moves back to the shut-off position. There is no idle position or intermediate speeds.

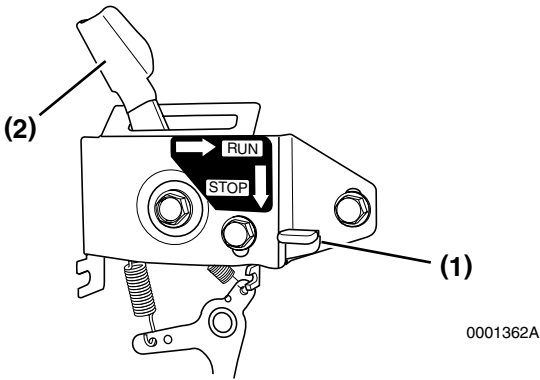

Figure 18

3. If your engine speed control is similar to **Figure 19**:
 - (a) Turn the engine speed control knob (**Figure 19, (1)**) to the left (**Figure 19, (2)**).
 - (b) Slide the engine speed control knob to the STOP position (**Figure 19, (3)**).
 - (c) Turn the engine speed control knob to the right (**Figure 19, (4)**) to tighten it.

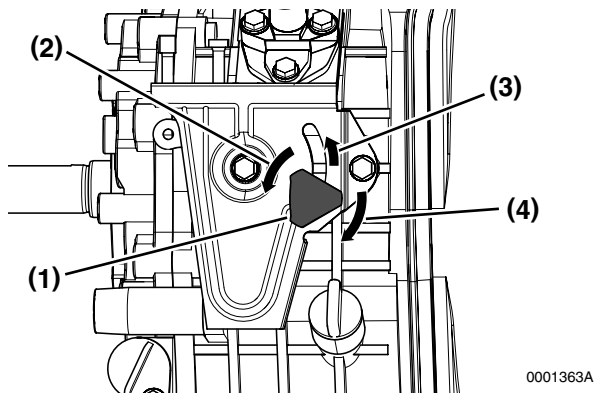

Figure 19

Electric Start Models

Turn the key to the OFF position (**Figure 20, (1)**) and remove it from the key switch.

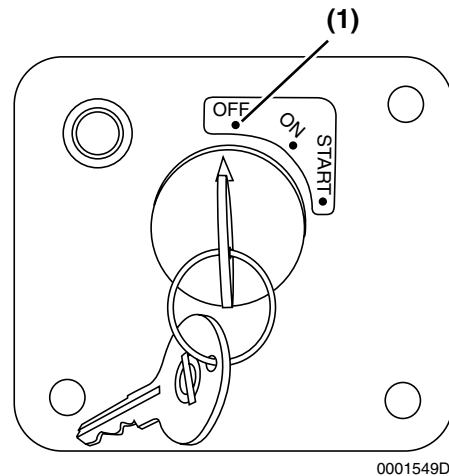

Figure 20

After The Engine Stops

1. Move the fuel cock lever to the closed position (**Figure 21, (1)**).

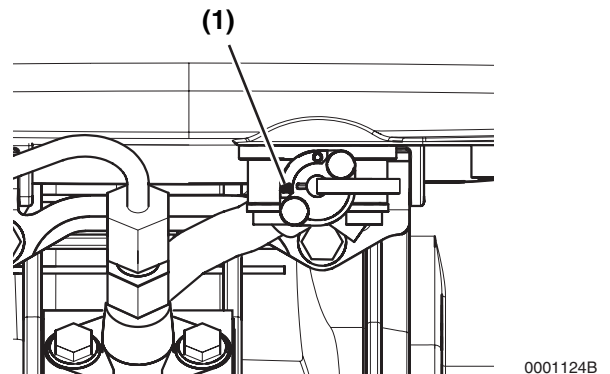

Figure 21

2. Slowly pull the recoil starter handle out to the point of resistance (the point in the compression stroke where the intake and exhaust valves are closed). This helps to prevent rust while the engine is not in use.
3. If the engine will not be used for six months or longer, follow the additional instructions in *Long Term Storage* on page 91.

This Page Intentionally Left Blank

PERIODIC MAINTENANCE

This section of the *Operation Manual* describes the procedures for proper care and maintenance of the engine.

CAUTION



NEVER permit anyone to operate the engine or driven machine without proper training.

- Read and understand this Operation Manual before you operate the machine to ensure that you follow safe operating practices and maintenance procedures.
- Machine safety signs and labels are additional reminders for safe operating and maintenance techniques.
- See your authorized Yanmar industrial engine dealer or distributor for additional training.

000002en

DANGER



EXPLOSION HAZARD!

- **NEVER** check the remaining battery charge by shorting out the terminals. This will result in a spark and may cause an explosion or fire. Use a hydrometer to check the remaining battery charge.
- If the electrolyte is frozen, slowly warm the battery before you recharge it.
- Failure to comply will result in death or serious injury.

000007en

DANGER



FIRE AND EXPLOSION HAZARD!

- Diesel fuel is extremely flammable and explosive under certain conditions.
- Only fill the fuel tank with diesel fuel. Filling the fuel tank with gasoline may result in a fire.
- NEVER refuel with the engine running.
- Wipe up all spills immediately.
- Keep sparks, open flames or any other form of ignition (match, cigarette, static electric source) away when fueling / refueling.
- NEVER overfill the fuel tank.
- Fill the fuel tank and store fuel in a well-ventilated area only.
- Failure to comply will result in death or serious injury.

000005en

DANGER



FIRE AND EXPLOSION HAZARD!

- Diesel fuel is extremely flammable and explosive under certain conditions.
- NEVER use diesel fuel as a cleaning agent.
- Failure to comply will result in death or serious injury.

000012en

DANGER



FIRE AND EXPLOSION HAZARD!

- Diesel fuel is extremely flammable and explosive under certain conditions.
- Before you operate the engine, check for fuel leaks. Replace rubberized fuel hoses every two years or every 2000 hours of engine operation, whichever comes first, even if the engine has been out of service. Rubberized fuel lines tend to dry out and become brittle after two years or 2000 hours of engine operation, whichever comes first.
- Failure to comply will result in death or serious injury.

000015en

DANGER



CRUSH HAZARD!

- When you need to transport an engine for repair, have a helper assist you to attach it to a hoist and load it on a truck.
- NEVER stand under a hoisted engine. If the hoist mechanism fails, the engine will fall on you, causing serious injury or death.
- Failure to comply will result in death or serious injury.

000008en

⚠ DANGER



FIRE AND EXPLOSION HAZARD!

- Diesel fuel is extremely flammable and explosive under certain conditions.
- Be sure to place the diesel fuel container on the ground when transferring the diesel fuel from the pump to the container. Hold the hose nozzle firmly against the side of the container while filling it. This prevents static electricity build-up which could cause sparks and ignite fuel vapors.
- NEVER place diesel fuel or other flammable material such as oil, hay or dried grass close to the engine during engine operation or shortly after shut down.
- Failure to comply will result in death or serious injury.

0000014en

⚠ DANGER



FIRE AND EXPLOSION HAZARD!

- Diesel fuel is extremely flammable and explosive under certain conditions.
- NEVER remove the fuel cap with the engine running.
- Failure to comply will result in death or serious injury.

0000011en

⚠ DANGER



FIRE AND EXPLOSION HAZARD!

- Only use the key switch to start the engine.
- NEVER jump start the engine. Sparks caused by jumping the battery to the starter terminals may cause a fire or explosion.
- Failure to comply will result in death or serious injury.

0000004en

⚠ DANGER



FIRE AND EXPLOSION HAZARD!

- Diesel fuel is extremely flammable and explosive under certain conditions.
- When you remove any fuel system component to perform maintenance (such as changing the fuel filter) place an approved container under the opening to catch the fuel.
- NEVER use a shop rag to catch the fuel. Vapors from the rag are extremely flammable and explosive.
- Wipe up any spills immediately.
- Wear eye protection. The fuel system is under pressure and fuel could spray out when you remove any fuel system component.
- Failure to comply will result in death or serious injury.

0000009en

WARNING



EXHAUST HAZARD!

- **NEVER** operate the engine in an enclosed area such as a garage, tunnel, underground room, manhole or ship's hold without proper ventilation.
- **NEVER** block windows, vents, or other means of ventilation if the engine is operating in an enclosed area. All internal combustion engines create carbon monoxide gas during operation. Accumulation of this gas within an enclosure could cause illness or even death.
- **Make sure that all connections are tightened to specifications after repair is made to the exhaust system.**
- **Failure to comply could result in death or serious injury.**

000003en

WARNING



BURN HAZARD!

- **Keep your hands and other body parts away from hot engine surfaces such as the muffler, exhaust pipe, turbocharger (if equipped) and engine block during operation and shortly after you shut the engine down. These surfaces are extremely hot while the engine is operating and could seriously burn you.**
- **Failure to comply could result in death or serious injury.**

0000015en

⚠ WARNING



SEVER HAZARD!

- Keep hands and other body parts away from moving / rotating parts such as the cooling fan / flywheel.
- Wear tight fitting clothing and keep your hair short or tie it back while the engine is running.
- Remove all jewelry before you operate or service the machine.
- NEVER start the engine in gear. Sudden movement of the engine and / or machine could cause death or serious personal injury.
- NEVER operate the engine without the guards in place.
- Before you start the engine make sure that all bystanders are clear of the area.
- Keep children and pets away while the engine is operating.
- Check before starting the engine that any tools or shop rags used during maintenance have been removed from the area.
- Failure to comply could result in death or serious injury.

000002enLV

⚠ WARNING



ALCOHOL AND DRUG HAZARD!

- NEVER operate the engine while you are under the influence of alcohol or drugs.
- NEVER operate the engine when you are feeling ill.
- Failure to comply could result in death or serious injury.

000004en

WARNING

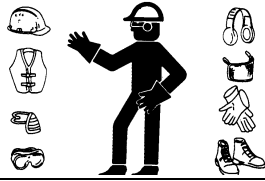

EXPOSURE HAZARD!

- Wear personal protective equipment such as gloves, work shoes, eye and hearing protection as required by the task at hand.
- NEVER wear jewelry, unbuttoned cuffs, ties or loose fitting clothing when you are working near moving / rotating parts such as the cooling fan, flywheel or PTO shaft.
- ALWAYS tie long hair back when you are working near moving / rotating parts such as a cooling fan, flywheel, or PTO shaft.
- NEVER operate the engine while wearing a headset to listen to music or radio because it will be difficult to hear the warning signals.
- Failure to comply could result in death or serious injury.

0000005en

WARNING



BURN HAZARD!

- Batteries contain sulfuric acid. NEVER allow battery fluid to come in contact with clothing, skin or eyes. Severe burns could result. ALWAYS wear safety goggles and protective clothing when servicing the battery. If contact with the skin and / or eyes should occur, flush with a large amount of water and obtain prompt medical treatment.
- Failure to comply could result in death or serious injury.

0000007en

WARNING



HIGH PRESSURE HAZARD!

- Avoid skin contact with the high pressure diesel fuel spray caused by a fuel system leak such as a broken fuel injection line. High pressure fuel can penetrate your skin and result in serious injury. If you are exposed to high pressure fuel spray, obtain prompt medical treatment.
- NEVER check for a fuel leak with your hands. ALWAYS use a piece of wood or cardboard. Have your authorized Yanmar industrial engine dealer or distributor repair the damage.
- Failure to comply could result in death or serious injury.

0000008en

⚠ WARNING



SHOCK HAZARD!

- Turn off the battery switch (if equipped) or disconnect the negative battery cable before servicing the electrical system.
- Check the electrical harnesses for cracks, abrasions, and damaged or corroded connectors. **ALWAYS** keep the connectors and terminals clean.
- Failure to comply could result in death or serious injury.

000009en

⚠ WARNING



BURN HAZARD!

- If you must drain the engine oil while it is still hot, stay clear of the hot engine oil to avoid being scalded. Make sure you wear eye protection.
- Failure to comply could result in death or serious injury.

000011en

⚠ WARNING



SEVER HAZARD!

- Stop the engine before you begin to service it.
- **NEVER** leave the key in the key switch when you are servicing the engine. Someone may accidentally start the engine and not realize you are servicing it. This could result in a serious injury.
- If you must service the engine while it is operating, remove all jewelry, tie long hair back, and keep your hands, other body parts and clothing away from moving / rotating parts.
- Failure to comply could result in death or serious injury.

000010en

⚠ CAUTION



FLYING OBJECT HAZARD!

- **ALWAYS** wear eye protection when servicing the engine and when using compressed air or high-pressure water. Dust, flying debris, compressed air, pressurized water or steam may injure your eyes.
- Failure to comply may result in minor or moderate injury.

000003en

CAUTION

- Only use diesel fuels recommended by Yanmar for the best engine performance, to prevent engine damage and to comply with EPA / ARB warranty requirements.
- Only use clean diesel fuel.
- NEVER remove inlet fuel screen from the filler port. If removed, dirt and debris could get into the fuel system causing it to clog.

000004enLV

CAUTION

- Only use the engine oil specified. Other engine oils may affect warranty coverage, cause internal engine components to seize, or shorten engine life.
- Prevent dirt and debris from contaminating the engine oil. Carefully clean the oil cap / dipstick and the surrounding area before you remove the cap.
- NEVER mix different types of engine oil. This may adversely affect the lubricating properties of the engine oil.
- NEVER overfill. Overfilling may result in white exhaust smoke, engine overspeed or internal damage.

000005en

CAUTION

- NEVER attempt to modify the engine's design or safety features such as defeating the engine speed limit control or the fuel injection quantity control.
- Failure to comply may impair the engine's safety and performance characteristics and shorten the engine's life. Any alterations to this engine may affect the warranty coverage of your engine. *See Yanmar Limited Warranty on page vii.*

0000044enLVOM

CAUTION

Observe the following environmental operating conditions to maintain engine performance and avoid premature engine wear:

- Avoid operating in extremely dusty conditions.
- Avoid operating in the presence of chemical gases or fumes.
- Avoid operating in a corrosive atmosphere such as salt water spray.
- NEVER install the engine in a floodplain unless proper precautions are taken to avoid being subject to a flood.
- NEVER expose the engine to the rain.

000003en

CAUTION

Observe the following environmental operating conditions to maintain engine performance and avoid premature engine wear:

- **NEVER** run the engine if the ambient temperature is above +104°F (+40°C) or below +14°F (-10°C)
 - ◆ If the ambient temperature exceeds +104°F (+40°C) the engine may overheat and cause the engine oil to break down.
 - ◆ If the ambient temperature falls below +14°F (-10°C) rubber components such as gaskets and seals will harden causing premature engine wear and damage.
 - ◆ Contact your authorized Yanmar industrial engine dealer or distributor if the engine will be operated in either temperature extreme.
- Contact your authorized Yanmar industrial engine dealer or distributor if you need to operate the engine at high altitudes. At high altitudes the engine will lose power, run rough, and produce exhaust gases that exceed the design specifications.

0000065enLV

CAUTION

NEVER hold the key in the START position for longer than 15 seconds or the starter motor will overheat.

0000007en

CAUTION

For maximum engine life, Yanmar recommends that when shutting the engine down, you allow the engine to idle, without load, for 5 minutes. This will allow the engine components that operate at high temperatures, such as the turbocharger (if equipped) and exhaust system, to cool slightly before the engine itself is shut down.

0000008en

CAUTION

NEVER use an engine starting aid such as ether. Engine damage will result.

0000009en

CAUTION

Make sure the engine is installed on a level surface. If a continuously running engine is installed at an angle greater than 20° (in any direction) or if an engine runs for short periods of time (less than 3 minutes) at an angle greater than 25° in any direction, engine oil may enter the combustion chamber causing excessive engine speed and generate white smoke. This may cause serious engine damage.

0000010enTNE

CAUTION

- **NEVER** overfill the engine with engine oil.
- **ALWAYS** keep the oil level between the upper and lower lines on the oil cap / dipstick.

0000015en

CAUTION

It is important to perform daily checks. See *Daily Checks* on page 34.

Periodic maintenance prevents unexpected downtime, reduces the number of accidents due to poor machine performance and helps extend the life of the engine.

0000060enLVOM

CAUTION

NEVER engage the starter motor while the engine is running. This may damage the starter motor pinion and / or ring gear.

0000012en

CAUTION

Protect the air cleaner, turbocharger (if equipped) and electric components from damage when you use steam or use high-pressure water to clean the engine.

0000014en

CAUTION

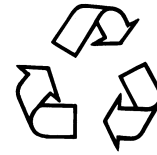

Be environmentally responsible. Follow these procedures for hazardous waste disposal. Failure to follow these procedures may seriously harm the environment.

- Follow the guidelines of the EPA or other governmental agency for the proper disposal of hazardous materials such as engine oil, diesel fuel and engine coolant. Consult the local authorities or reclamation facility.
- **NEVER** dispose of hazardous materials irresponsibly by dumping them into a sewer, on the ground or into ground water or waterways.

0000013en

CAUTION

Establish a periodic maintenance plan according to the engine application and make sure you perform the required periodic maintenance at intervals indicated. Failure to follow these guidelines will impair the engine's safety and performance characteristics, shorten the engine's life and may affect the warranty coverage on your engine. See *Yanmar Limited Warranty* on page vii.

Consult your authorized Yanmar industrial engine dealer or distributor for assistance when checking items marked with a ●.

0000024enLVOM

CAUTION

- When the engine is operated in dusty conditions, clean the air cleaner element more frequently.
- NEVER operate the engine with the air cleaner or element(s) removed. This may cause foreign material to enter the engine and damage it.

0000026en

CAUTION

The maximum air intake restriction shall be:

- L48V: 0.10 psi (0.69 kPa; 70 mm Aq) or less
- L70V: 0.20 psi (1.37 kPa; 140 mm Aq) or less
- L100V: 0.21 psi (1.47 kPa; 150 mm Aq) or less.

Clean or replace the air cleaner element if the air intake restriction exceeds the above mentioned value.

0000046enLV

CAUTION

The tightening torque in the *Standard Torque Chart (page 67)* should be carefully observed.

- Apply 60% torque to bolts that are not listed.
- Apply 80% torque when tightened to aluminum alloy.



0000023enLVOM

PRECAUTIONS

The Importance of Periodic Maintenance

Engine deterioration and wear occurs in proportion to length of time the engine has been in service and the conditions the engine is subject to during operation. Periodic maintenance prevents unexpected downtime, reduces the number of accidents due to poor machine performance and helps extend the life of the engine.

Performing Periodic Maintenance

 WARNING	
	
EXHAUST HAZARD!	
<ul style="list-style-type: none">• NEVER operate the engine in an enclosed area such as a garage, tunnel, underground room, manhole or ship's hold without proper ventilation.• NEVER block windows, vents, or other means of ventilation if the engine is operating in an enclosed area. All internal combustion engines create carbon monoxide gas during operation. Accumulation of this gas within an enclosure could cause illness or even death.• Make sure that all connections are tightened to specifications after repair is made to the exhaust system.• Failure to comply could result in death or serious injury.	
000003en	

Perform periodic maintenance procedures in an open, level area free from traffic. If possible, perform the procedures indoors to prevent environmental conditions, such as rain, wind, or snow, from damaging the machine.

The Importance of Daily Checks

Periodic Maintenance Schedules assume that the daily checks are performed on a regular basis. Make it a habit of performing daily checks before the start of each shift. *See Daily Checks on page 34.*

Keep a Log of Engine Hours and Daily Checks

Keep a log of the number of hours the engine is run each day and a log of the daily checks performed. Also note the date, type of repair (e.g., replaced alternator), and parts needed for any service needed between the periodic maintenance intervals. Periodic maintenance intervals are every 50, 200, 400, 1000, 1500 and 2000 engine hours. Failure to perform periodic maintenance will shorten the life of the engine.

Yanmar Replacement Parts

Yanmar recommends that you use genuine Yanmar parts when replacement parts are needed. Genuine replacement parts help ensure long engine life.

Tools Required

Before you start any periodic maintenance procedure make sure you have the tools you need to perform all of the required tasks.

Ask Your Authorized Yanmar Industrial Engine Dealer or Distributor For Help

Our professional service technicians have the expertise and skills to help you with any maintenance or service related procedures you need help with.

Required EPA / ARB Maintenance - USA Only

To maintain optimum engine performance and compliance with the Environmental Protection Agency (EPA) Regulations Non-road Engines and the California Air Resources Board (ARB, California), it is essential that you follow the *Periodic Maintenance Schedule on page 68* and *Periodic Maintenance Procedures which start on page 70*.

EPA / ARB Installation Requirements - USA Only

The following are the installation requirements for the EPA / ARB. Unless these requirements are met, the exhaust gas emissions will not be within the limits specified by the EPA and ARB.

Maximum Exhaust Gas Restriction shall be:

- L48V: 0.53 psi (3.628 kPa; 370 mm Aq) or less
- L70V: 0.54 psi (3.727 kPa; 380 mm Aq) or less
- L100V: 0.63 psi (4.315 kPa; 440 mm Aq) or less

Maximum Exhaust Gas Restriction shall be:

- L48V: 0.10 psi (0.69 kPa; 70 mm Aq) or less
- L70V: 0.20 psi (1.37 kPa; 140 mm Aq) or less
- L100V: 0.21 psi (1.47 kPa; 150 mm Aq) or less

Clean or replace the air cleaner element if the air intake restriction exceeds the above mentioned value.

Tightening Fasteners

Use the correct amount of torque when you tighten fasteners on the machine. Applying excessive torque may damage the fastener or component and not enough torque may cause a leak or component failure.

CAUTION

The tightening torque in the *Standard Torque Chart (page 67)* should be carefully observed.

- **Apply 60% torque to bolts that are not listed.**
- **Apply 80% torque when tightened to aluminum alloy.**

0000023enLVOM

STANDARD TORQUE CHART

Thread size × Pitch mm		M6×1.0	M8×1.25	M10×1.5	M12×1.75	M14×1.5	M16×1.5
Tightening Torque	in lbs	96.0 ± 9.0	-	-	-	-	-
	ft lbs	-	19.0 ± 2.0	36.0 ± 4.0	65.0 ± 7.0	101.0 ± 7.0	167.0 ± 7.0
	N·m	10.8 ± 1.0	25.5 ± 2.9	49.0 ± 4.9	88.3 ± 9.8	137.0 ± 9.8	226.0 ± 9.8
	kgf·m	1.1 ± 0.1	2.6 ± 0.3	5.0 ± 0.5	9.0 ± 1.0	14.0 ± 1.5	23.0 ± 2.0

PERIODIC MAINTENANCE SCHEDULE

Daily and periodic maintenance is important to keep the engine in good operating condition. The following is a summary of maintenance items by periodic maintenance intervals. Periodic maintenance intervals vary depending on engine application, loads, diesel fuel and engine oil used and are hard to establish definitively. The following should be treated only as a general guideline.

CAUTION

Establish a periodic maintenance plan according to the engine application and make sure you perform the required periodic maintenance at intervals indicated. Failure to follow these guidelines will impair the engine's safety and performance characteristics, shorten the engine's life and may affect the warranty coverage on your engine. See Yanmar Limited Warranty on page vii.

Consult your authorized Yanmar industrial engine dealer or distributor for assistance when checking items marked with a ●.

0000024enLVOM

PERIODIC MAINTENANCE

○: Check ◇: Replace ●: Contact your authorized Yanmar industrial engine dealer or distributor for these maintenance services.

System	Check Item	Daily	Periodic Maintenance Interval					
			Every 50 hours	Every 200 hours	Every 400 hours	Every 1000 hours	Every 1500 hours	Every 2000 hours
Air Intake	Clean or Replace Air Cleaner Element - May Need More Frequent Service in Dusty Conditions			○				
Cylinder Head	Adjust Intake / Exhaust Valve Clearance				●			
	Check Compression					●		
Electrical Equipment	Check Battery & Add Water as Necessary	○ before operation						
	Check Battery Indicator (If Equipped) and Other Driven Machine Indicators (If Equipped)	○ when engine is started						
Emission Control Warranty	Inspect, Clean & Test Fuel Injection Nozzle						●	
Engine Oil	Check Engine Oil Level & Add Engine Oil As Necessary	○ before operation						
	Drain and Refill Engine Oil		◇	◇ 2nd & after				
	Clean Engine Oil Filter - Replace If Damaged		◇ 1st time		◇ 2nd & after			
	Check for Engine Oil Leakage	○ before & after operation						
Engine Speed Control	Check for Proper Operation Verify Adjustment	○ 1st time		○ 2nd & after				
Exhaust System	Check Spark Arrestor for Clogging	○ before operation						
Fuel	Check Fuel Tank Level & Add Fuel As Necessary	○ before operation						
	Drain & Clean Fuel Tank			○				
	Clean Inlet Fuel Screen		○					
	Replace Outlet Fuel Filter			○	◇			
	Check for Fuel Leakage	○ before & after operation						
Hoses	Replace Fuel System Hose(s)						● or every 2 yrs. whichever comes first	

PERIODIC MAINTENANCE



PERIODIC MAINTENANCE PROCEDURES

Daily, Before Operation

Perform the following maintenance daily before operation.

- Check Battery (If Equipped)
- Check Battery Indicator (If Equipped)
- Check Engine Oil Level
- Check For Engine Oil Leakage
- Check Engine Speed Control (First Time Only)
- Check Spark Arrestor (If Equipped)
- Check Fuel Level
- Check For Fuel Leakage

Check Battery (If Equipped)

 DANGER

<p>EXPLOSION HAZARD!</p> <ul style="list-style-type: none">• NEVER check the remaining battery charge by shorting out the terminals. This will result in a spark and may cause an explosion or fire. Use a hydrometer to check the remaining battery charge.• If the electrolyte is frozen, slowly warm the battery before you recharge it.• Failure to comply will result in death or serious injury. <p style="text-align: right;"><small>000007en</small></p>

 WARNING

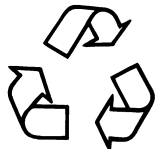
<p>BURN HAZARD!</p> <ul style="list-style-type: none">• Batteries contain sulfuric acid. NEVER allow battery fluid to come in contact with clothing, skin or eyes. Severe burns could result. ALWAYS wear safety goggles and protective clothing when servicing the battery. If contact with the skin and / or eyes should occur, flush with a large amount of water and obtain prompt medical treatment.• Failure to comply could result in death or serious injury. <p style="text-align: right;"><small>000007en</small></p>

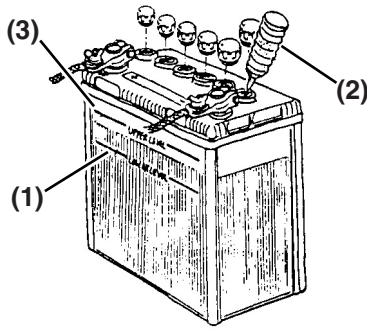
CAUTION

<p>Be environmentally responsible. Follow these procedures for hazardous waste disposal. Failure to follow these procedures may seriously harm the environment.</p> <ul style="list-style-type: none">• Follow the guidelines of the EPA or other governmental agency for the proper disposal of hazardous materials such as engine oil, diesel fuel and engine coolant. Consult the local authorities or reclamation facility.• NEVER dispose of hazardous materials irresponsibly by dumping them into a sewer, on the ground or into ground water or waterways. <p style="text-align: right;"><small>000013en</small></p>



0000067A

Figure 1

- When the amount of fluid nears the lower limit (**Figure 1, (1)**), fill with distilled water (**Figure 1, (2)**) so it is at the upper limit (**Figure 1, (3)**). If operation continues with insufficient battery fluid, the battery life is shortened, and the battery may overheat and explode. During the summer, check the fluid level more often than specified.
- If the engine cranking speed is so slow that the engine does not start, recharge the battery.
- If the engine still will not start after charging, have your authorized Yanmar industrial engine dealer or distributor check the battery and the engine's starting system.

If operating the machine where the ambient temperature could drop to 14°F (-10°C) or less, remove the battery from the machine at the end of the day. Store the battery in a warm place until the next use. This will help start the engine easily at low ambient temperatures.

Check Battery Indicator (If Equipped)

Visually check the battery indicator (if equipped) and any other indicator provided by the driven machine manufacturer. *See Indicators and Controls – Electric Starter on page 21.*

Check Engine Oil Level

CAUTION

- Only use the engine oil specified. Other engine oils may affect warranty coverage, cause internal engine components to seize, or shorten engine life.
- Prevent dirt and debris from contaminating the engine oil. Carefully clean the oil cap / dipstick and the surrounding area before you remove the cap.
- NEVER mix different types of engine oil. This may adversely affect the lubricating properties of the engine oil.
- NEVER overfill. Overfilling may result in white exhaust smoke, engine overspeed or internal damage.

000005en

CAUTION

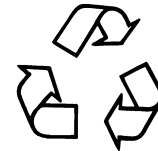

Be environmentally responsible. Follow these procedures for hazardous waste disposal. Failure to follow these procedures may seriously harm the environment.

- Follow the guidelines of the EPA or other governmental agency for the proper disposal of hazardous materials such as engine oil, diesel fuel and engine coolant. Consult the local authorities or reclamation facility.
- NEVER dispose of hazardous materials irresponsibly by dumping them into a sewer, on the ground or into ground water or waterways.

0000013en

Before you operate the engine check the engine oil level. *See Checking Engine Oil on page 33.*

Check For Engine Oil Leakage

⚠ WARNING



BURN HAZARD!

- Keep your hands and other body parts away from hot engine surfaces such as the muffler, exhaust pipe, turbocharger (if equipped) and engine block during operation and shortly after you shut the engine down. These surfaces are extremely hot while the engine is operating and could seriously burn you.
- Failure to comply could result in death or serious injury.

0000015en

Before you operate the engine check for any engine oil leaks. If you discover an engine oil leak see your authorized Yanmar industrial engine dealer or distributor to repair the engine.

Check Engine Speed Control (First Time Only)

Before you operate the driven machine for the first time check the engine speed control. See the instructions for your driven machine for proper adjustments.

1. Check the engine speed control for smooth operation and lubricate or clean as necessary.
2. Check engine speed control for proper adjustments.

Check Spark Arrestor (If Equipped)

⚠ WARNING



BURN HAZARD!

- Keep your hands and other body parts away from hot engine surfaces such as the muffler, exhaust pipe, turbocharger (if equipped) and engine block during operation and shortly after you shut the engine down. These surfaces are extremely hot while the engine is operating and could seriously burn you.
- Failure to comply could result in death or serious injury.

0000015en

A clogged spark arrestor hinders exhaust gas flow which reduces engine output, increases fuel consumption, and makes starting difficult. Clean the spark arrestor regularly.

Clean the spark arrestor (**Figure 2, (1)**) as follows:

1. Remove the locknut (**Figure 2, (2)**), end cap (**Figure 2, (3)**) and diffuser discs (**Figure 2, (4)**) from the spark arrestor.

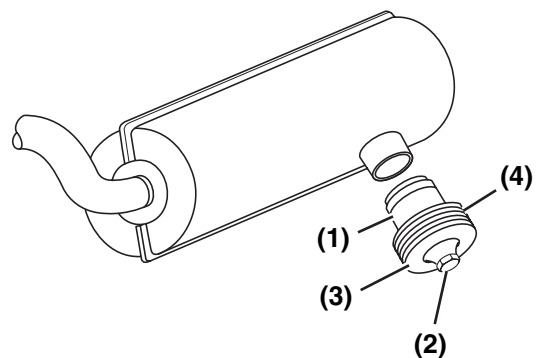





0001567A

Figure 2

2. Clean any carbon deposits from the spark arrestor.
3. Install the diffuser discs (**Figure 2, (4)**) and end cap (**Figure 2, (3)**) on the spark arrestor (**Figure 2, (1)**) and secure with the locknut (**Figure 2, (2)**).

Check Fuel Level

 DANGER

<p>FIRE AND EXPLOSION HAZARD!</p> <ul style="list-style-type: none"> • Diesel fuel is extremely flammable and explosive under certain conditions. • Only fill the fuel tank with diesel fuel. Filling the fuel tank with gasoline may result in a fire. • NEVER refuel with the engine running. • Wipe up all spills immediately. • Keep sparks, open flames or any other form of ignition (match, cigarette, static electric source) away when fueling / refueling. • NEVER overfill the fuel tank. • Fill the fuel tank and store fuel in a well-ventilated area only. • Failure to comply will result in death or serious injury. <p style="text-align: right; font-size: small;">000005en</p>

 DANGER

<p>FIRE AND EXPLOSION HAZARD!</p> <ul style="list-style-type: none"> • Diesel fuel is extremely flammable and explosive under certain conditions. • Be sure to place the diesel fuel container on the ground when transferring the diesel fuel from the pump to the container. Hold the hose nozzle firmly against the side of the container while filling it. This prevents static electricity build-up which could cause sparks and ignite fuel vapors. • NEVER place diesel fuel or other flammable material such as oil, hay or dried grass close to the engine during engine operation or shortly after shut down. • Failure to comply will result in death or serious injury. <p style="text-align: right; font-size: small;">000014en</p>

⚠ DANGER



FIRE AND EXPLOSION HAZARD!

- Diesel fuel is extremely flammable and explosive under certain conditions.
- Before you operate the engine, check for fuel leaks. Replace rubberized fuel hoses every two years or every 2000 hours of engine operation, whichever comes first, even if the engine has been out of service. Rubberized fuel lines tend to dry out and become brittle after two years or 2000 hours of engine operation, whichever comes first.
- Failure to comply will result in death or serious injury.

0000015en

CAUTION

- Only use diesel fuels recommended by Yanmar for the best engine performance, to prevent engine damage and to comply with EPA / ARB warranty requirements.
- Only use clean diesel fuel.
- NEVER remove inlet fuel screen from the filler port. If removed, dirt and debris could get into the fuel system causing it to clog.

000004enLV

Before you operate the engine check the fuel level.
See *Filling the Fuel Tank* on page 30.

Check For Fuel Leakage

⚠ WARNING



HIGH PRESSURE HAZARD!

- Avoid skin contact with the high pressure diesel fuel spray caused by a fuel system leak such as a broken fuel injection line. High pressure fuel can penetrate your skin and result in serious injury. If you are exposed to high pressure fuel spray, obtain prompt medical treatment.
- NEVER check for a fuel leak with your hands. ALWAYS use a piece of wood or cardboard. Have your authorized Yanmar industrial engine dealer or distributor repair the damage.
- Failure to comply could result in death or serious injury.

000008en

⚠ WARNING



BURN HAZARD!

- Keep your hands and other body parts away from hot engine surfaces such as the muffler, exhaust pipe, turbocharger (if equipped) and engine block during operation and shortly after you shut the engine down. These surfaces are extremely hot while the engine is operating and could seriously burn you.
- Failure to comply could result in death or serious injury.

0000015en

CAUTION

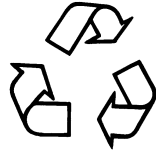

Be environmentally responsible. Follow these procedures for hazardous waste disposal. Failure to follow these procedures may seriously harm the environment.

- Follow the guidelines of the EPA or other governmental agency for the proper disposal of hazardous materials such as engine oil, diesel fuel and engine coolant. Consult the local authorities or reclamation facility.
- **NEVER** dispose of hazardous materials irresponsibly by dumping them into a sewer, on the ground or into ground water or waterways.

0000013en

Before you operate the engine check for any fuel leaks. NEVER use your hands! If you discover a fuel leak see your authorized Yanmar industrial engine dealer or distributor to repair the engine.

Daily, After Operation

- Check For Engine Oil Leakage
- Check For Fuel Leakage

Check For Engine Oil Leakage

WARNING



BURN HAZARD!



- Keep your hands and other body parts away from hot engine surfaces such as the muffler, exhaust pipe, turbocharger (if equipped) and engine block during operation and shortly after you shut the engine down. These surfaces are extremely hot while the engine is operating and could seriously burn you.
- **Failure to comply could result in death or serious injury.**



0000015en

After you shut down the engine check for any engine oil leaks. If you discover an engine oil leak see your authorized Yanmar industrial engine dealer or distributor to repair the engine.

PERIODIC MAINTENANCE

Check For Fuel Leakage

 WARNING

<p>HIGH PRESSURE HAZARD!</p> <ul style="list-style-type: none">• Avoid skin contact with the high pressure diesel fuel spray caused by a fuel system leak such as a broken fuel injection line. High pressure fuel can penetrate your skin and result in serious injury. If you are exposed to high pressure fuel spray, obtain prompt medical treatment.• NEVER check for a fuel leak with your hands. ALWAYS use a piece of wood or cardboard. Have your authorized Yanmar industrial engine dealer or distributor repair the damage.• Failure to comply could result in death or serious injury.
<small>000008en</small>

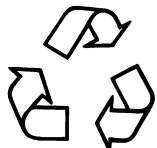
 WARNING

<p>BURN HAZARD!</p> <ul style="list-style-type: none">• Keep your hands and other body parts away from hot engine surfaces such as the muffler, exhaust pipe, turbocharger (if equipped) and engine block during operation and shortly after you shut the engine down. These surfaces are extremely hot while the engine is operating and could seriously burn you.• Failure to comply could result in death or serious injury.
<small>0000015en</small>

CAUTION

<p>Be environmentally responsible. Follow these procedures for hazardous waste disposal. Failure to follow these procedures may seriously harm the environment.</p> <ul style="list-style-type: none">• Follow the guidelines of the EPA or other governmental agency for the proper disposal of hazardous materials such as engine oil, diesel fuel and engine coolant. Consult the local authorities or reclamation facility.• NEVER dispose of hazardous materials irresponsibly by dumping them into a sewer, on the ground or into ground water or waterways.
<small>0000013en</small>

After you shut down the engine check for any fuel leaks. NEVER use your hands! If you discover a fuel leak see your authorized Yanmar industrial engine dealer or distributor to repair the engine.

After Initial 50 Hours of Operation

Perform the following maintenance after the initial 50 hours of operation.

- Replace Engine Oil
- Clean / Inspect Engine Oil Filter

Replace Engine Oil

⚠ WARNING



BURN HAZARD!

- If you must drain the engine oil while it is still hot, stay clear of the hot engine oil to avoid being scalded. Make sure you wear eye protection.
- Failure to comply could result in death or serious injury.

0000011en

⚠ WARNING

SUDDEN MOVEMENT HAZARD!

- Allow the engine to warm up for at least 5 minutes to allow the engine idle speed to return to normal before engaging the transmission or any PTO attachments. Engaging the transmission or PTO at an elevated engine speed could result in an unexpected movement of the equipment.
- Failure to comply could result in death or serious injury.

0000006en

CAUTION

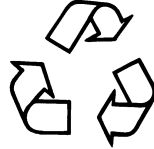

Be environmentally responsible. Follow these procedures for hazardous waste disposal. Failure to follow these procedures may seriously harm the environment.

- Follow the guidelines of the EPA or other governmental agency for the proper disposal of hazardous materials such as engine oil, diesel fuel and engine coolant. Consult the local authorities or reclamation facility.
- NEVER dispose of hazardous materials irresponsibly by dumping them into a sewer, on the ground or into ground water or waterways.

0000013en

CAUTION

- Only use the engine oil specified. Other engine oils may affect warranty coverage, cause internal engine components to seize, or shorten engine life.
- Prevent dirt and debris from contaminating the engine oil. Carefully clean the oil cap / dipstick and the surrounding area before you remove the cap.
- NEVER mix different types of engine oil. This may adversely affect the lubricating properties of the engine oil.
- NEVER overfill. Overfilling may result in white exhaust smoke, engine overspeed or internal damage.

0000005en

PERIODIC MAINTENANCE

The engine oil on a new engine becomes contaminated from the initial break-in of internal parts. The initial 50 hour oil change and filter cleaning is very important.

Drain the engine oil as follows:

1. Make sure the engine is level.
2. Start the engine and bring it up to operating temperature.
3. Stop the engine.
4. Remove the oil cap / dipstick (**Figure 3, (1)**) to allow the engine oil to drain more easily.

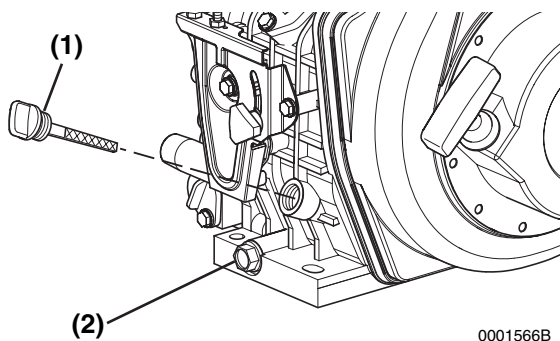
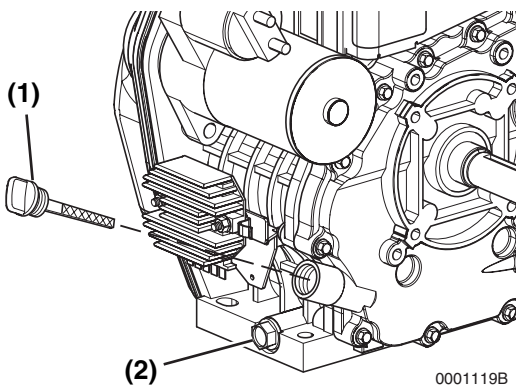

Figure 3

5. Position a container under the engine to collect waste oil.
6. Remove the drain plug located on the bottom of the cylinder block (**Figure 3, (2)**). Allow oil to drain.
7. After all oil has been drained from the engine, install the drain plug (**Figure 3, (2)**) and tighten to 14-17 ft lbs (19.6-23.5 N•m, 2.0-2.4 kgf•m).
8. Dispose of used oil properly.

Clean / Inspect Engine Oil Filter

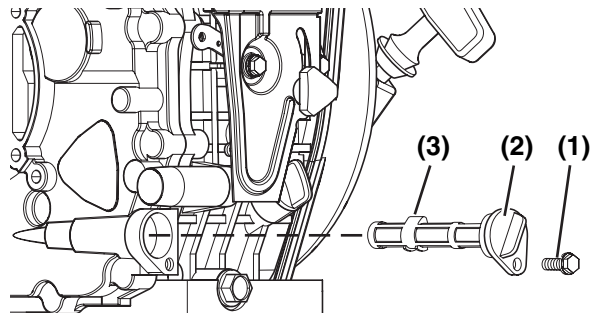

Figure 4

Clean / inspect the engine oil filter as follows:

1. Remove the oil filter retaining bolt (**Figure 4, (1)**).
2. Pull the oil filter cap (**Figure 4, (2)**) out and remove the oil filter (**Figure 4, (3)**).
3. Clean the oil filter or replace if damaged.
4. Install the oil filter (**Figure 4, (3)**).
5. Make sure the oil filter cap is fully seated (**Figure 4, (2)**).
6. Install and tighten the oil filter retaining bolt (**Figure 4, (1)**).

Applicable Engine Oil Filter Part No.

L48V, L70V and L100V

114250-35070

7. Add new engine oil to the engine as specified in *Adding Engine Oil on page 33*.

CAUTION

- **NEVER** overfill the engine with engine oil.
- **ALWAYS** keep the oil level between the upper and lower lines on the oil cap / dipstick.

0000015en

8. Warm up the engine by running it for 5 minutes and check for any engine oil leaks.
9. After engine is warm, shut it off and let it sit for 10 minutes.

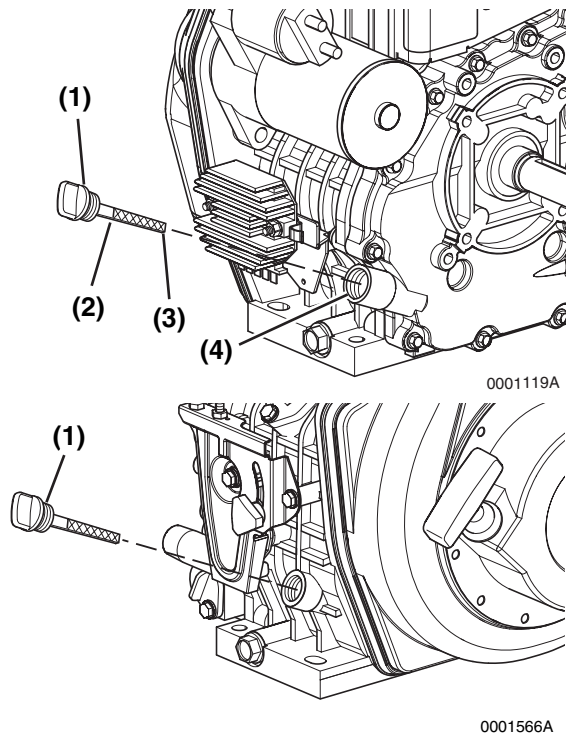

Figure 5

10. Recheck the engine oil level by fully inserting, but not screwing in, the dipstick.
11. Add engine oil (**Figure 5, (4)**) as needed until the level is between the upper (**Figure 5, (2)**) and lower lines (**Figure 5, (3)**) on the oil cap / dipstick (**Figure 5, (1)**).
12. Replace the oil cap / dipstick (**Figure 5, (1)**) and tighten by hand. Over-tightening may damage the cap. If any engine oil is spilled, wipe it away with a clean cloth.

Every 50 Hours of Operation

Perform the following maintenance every 50 hours of operation.

- Clean Inlet Fuel Screen

Clean Inlet Fuel Screen

! DANGER



FIRE AND EXPLOSION HAZARD!

- Diesel fuel is extremely flammable and explosive under certain conditions.
- When you remove any fuel system component to perform maintenance (such as changing the fuel filter) place an approved container under the opening to catch the fuel.
- **NEVER** use a shop rag to catch the fuel. Vapors from the rag are extremely flammable and explosive.
- Wipe up any spills immediately.
- Wear eye protection. The fuel system is under pressure and fuel could spray out when you remove any fuel system component.
- Failure to comply will result in death or serious injury.

000009en

1. Clean the area around the fuel cap (**Figure 6, (1)**).
2. Remove the fuel cap (**Figure 6, (1)**) from the fuel tank (**Figure 6, (2)**).

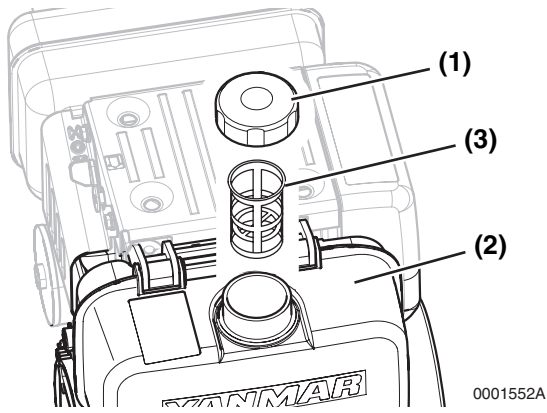

Figure 6

3. Lift out the inlet fuel screen (**Figure 6, (3)**).
4. Clean the inlet fuel screen or replace if damaged.
5. Install the inlet fuel screen (**Figure 6, (3)**).
6. Replace the fuel cap (**Figure 6, (1)**) and hand tighten. Overtightening the fuel cap will damage it.

Applicable Inlet Fuel Screen Part No.	
L48V, L70V and L100V	114250-55100

Every 200 Hours of Operation

Perform the following maintenance every 200 hours of operation.

- Clean Air Cleaner Element
- Replace Engine Oil and Clean / Inspect Engine Oil Filter
- Check Engine Speed Control
- Drain the Fuel Tank and Replace Outlet Fuel Filter

Clean Air Cleaner Element

⚠ CAUTION



FLYING OBJECT HAZARD!

- **ALWAYS** wear eye protection when servicing the engine and when using compressed air or high-pressure water. Dust, flying debris, compressed air, pressurized water or steam may injure your eyes.
- Failure to comply may result in minor or moderate injury.

000003en

CAUTION

- When the engine is operated in dusty conditions, clean the air cleaner element more frequently.
- **NEVER** operate the engine with the air cleaner or element(s) removed. This may cause foreign material to enter the engine and damage it.

0000026en

The engine performance is adversely affected when the air cleaner element is clogged with dust. Be sure to clean the air filter element periodically.

1. Remove the wing nut (**Figure 7, (1)**).
2. Remove the air cleaner cover (**Figure 7, (2)**).

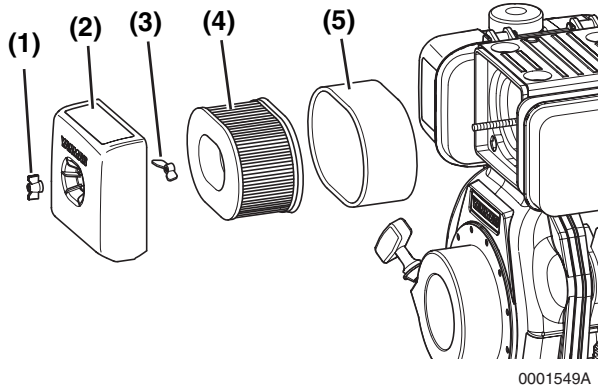

Figure 7

3. Remove the wing nut (**Figure 7, (3)**).
4. Remove the air cleaner element (**Figure 7, (4)**) and outer foam element (**Figure 7, (5)**).
5. Blow air through both elements using 42-71 psi (0.29–0.49MPa, 3.0–5.0kgf/cm²) compressed air to remove the particulates. Use the lowest possible air pressure to remove the dust without damaging the elements.
6. If either element is damaged replace both of them (they are not sold individually).

Applicable Air Cleaner Element Part No.	
L48V	114250-12581
L70V and L100V	114210-12590

7. Clean the inside of the air cleaner cover (**Figure 7, (2)**).
8. Install the air cleaner element (**Figure 7, (4)**) into the air cleaner case.
9. Slide the outer foam element (**Figure 7, (5)**) over the air cleaner element (**Figure 7, (4)**).
10. Install the wing nut (**Figure 7, (3)**) and hand tighten. Overtightening the wing nut will damage the air cleaner assembly.
11. Install the air cleaner cover (**Figure 7, (2)**).

12. Install the wing nut (**Figure 7, (1)**) and hand tighten. Overtightening the wing nut will damage the air cleaner assembly.

Replace Engine Oil and Clean / Inspect Engine Oil Filter

CAUTION

- Only use the engine oil specified. Other engine oils may affect warranty coverage, cause internal engine components to seize, or shorten engine life.
- Prevent dirt and debris from contaminating the engine oil. Carefully clean the oil cap / dipstick and the surrounding area before you remove the cap.
- NEVER mix different types of engine oil. This may adversely affect the lubricating properties of the engine oil.
- NEVER overfill. Overfilling may result in white exhaust smoke, engine overspeed or internal damage.

000005en

CAUTION

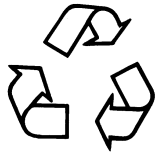

Be environmentally responsible. Follow these procedures for hazardous waste disposal. Failure to follow these procedures may seriously harm the environment.

- Follow the guidelines of the EPA or other governmental agency for the proper disposal of hazardous materials such as engine oil, diesel fuel and engine coolant. Consult the local authorities or reclamation facility.
- **NEVER** dispose of hazardous materials irresponsibly by dumping them into a sewer, on the ground or into ground water or waterways.

0000013en

Change the engine oil every 200 hours of operation after the initial change at 50 hours. Clean and inspect the engine oil filter at the same time. See *Replace Engine Oil* on page 77.

Check Engine Speed Control

After you operate the engine for 200 hours, check the engine speed control. See the instructions for your driven machine for proper adjustments.

1. Check the engine speed control for smooth operation and lubricate or clean as necessary.
2. Check engine speed control for proper adjustments.

Drain the Fuel Tank and Replace Outlet Fuel Filter

DANGER



FIRE AND EXPLOSION HAZARD!

- Diesel fuel is extremely flammable and explosive under certain conditions.
- When you remove any fuel system component to perform maintenance (such as changing the fuel filter) place an approved container under the opening to catch the fuel.
- **NEVER** use a shop rag to catch the fuel. Vapors from the rag are extremely flammable and explosive.
- Wipe up any spills immediately.
- Wear eye protection. The fuel system is under pressure and fuel could spray out when you remove any fuel system component.
- **Failure to comply will result in death or serious injury.**

0000009en

CAUTION

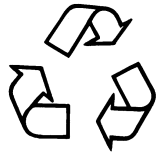

Be environmentally responsible. Follow these procedures for hazardous waste disposal. Failure to follow these procedures may seriously harm the environment.

- Follow the guidelines of the EPA or other governmental agency for the proper disposal of hazardous materials such as engine oil, diesel fuel and engine coolant. Consult the local authorities or reclamation facility.
- NEVER dispose of hazardous materials irresponsibly by dumping them into a sewer, on the ground or into ground water or waterways.

0000013en

1. Position an approved container under the fuel tank to collect the fuel.
2. Remove the fuel cap (Figure 8, (1)).
3. Remove the fuel tank drain plug (Figure 8, (2)) and gasket (Figure 8, (3)) to drain the fuel.

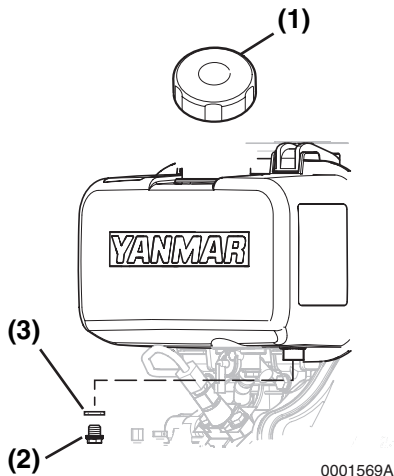
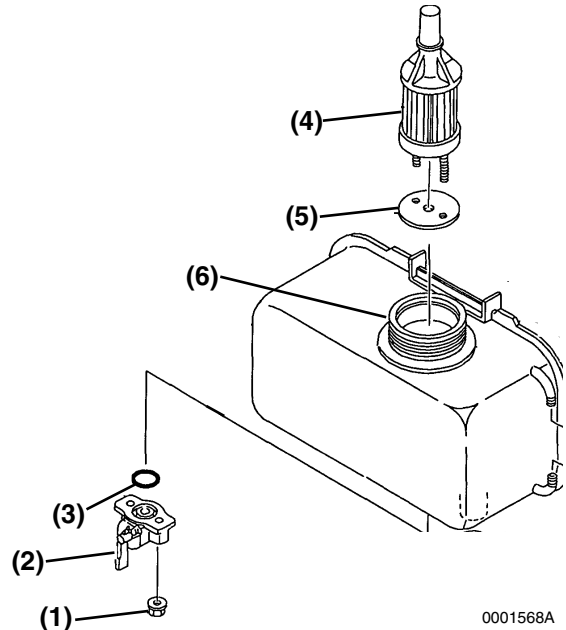

Figure 8

0001569A

4. Loosen the fuel cock nuts (Figure 9, (1)) on either side of the fuel cock (Figure 9, (2)).
5. Remove and discard the O-ring (Figure 9, (3)).
6. Pull the outlet fuel filter (Figure 9, (4)) and gasket (Figure 9, (5)) out of the fuel tank filler port (Figure 9, (6)).



0001568A

Figure 9

7. Install a new outlet fuel filter (Figure 9, (4)) and gasket (Figure 9, (5)) through the fuel tank filler port (Figure 9, (6)) and seat in the fuel tank.

Applicable Outlet Fuel Filter Part No.

L48V, L70V and L100V

114250-55121

Applicable O-Ring Part No.

L48V, L70V and L100V

24341-000150

8. Install a new O-ring (Figure 9, (3)) on the fuel cock (Figure 9, (2)) and fasten the assembly to the fuel tank using the fuel cock nuts (Figure 9, (1)).
9. Tighten the fuel tank drain plug (Figure 8, (2)) with new gasket (Figure 8, (3)).

PERIODIC MAINTENANCE

10. Replace the fuel cap (**Figure 8, (1)**) and hand tighten. Overtightening the fuel cap will damage it. Refill fuel tank. See *Filling the Fuel Tank* on page 30.

Every 400 Hours of Operation

Perform the following maintenance every 400 hours of operation.

- **Adjust Intake and Exhaust Valve Clearance**

Adjust Intake and Exhaust Valve Clearance

⚠ WARNING



HIGH PRESSURE HAZARD!

- **Avoid skin contact with the high pressure diesel fuel spray caused by a fuel system leak such as a broken fuel injection line. High pressure fuel can penetrate your skin and result in serious injury. If you are exposed to high pressure fuel spray, obtain prompt medical treatment.**
- **NEVER check for a fuel leak with your hands. ALWAYS use a piece of wood or cardboard. Have your authorized Yanmar industrial engine dealer or distributor repair the damage.**
- **Failure to comply could result in death or serious injury.**

000008en

Proper operation of the intake and exhaust valves is required to obtain optimum engine performance. See your authorized Yanmar industrial engine dealer or distributor for this service.

Every 1000 Hours of Operation

Perform the following maintenance every 1000 hours of operation.

- **Check Compression**

Check Compression



Checking the engine compression is required every 1000 hours to obtain optimum engine performance. See your authorized Yanmar industrial engine dealer or distributor for this service.

Every 1500 Hours of Operation

Perform the following maintenance every 1500 hours of operation.

- **Inspect, Clean and Test Fuel Injection Nozzle**

Inspect, Clean and Test Fuel Injection Nozzle

 WARNING

<p style="text-align: center;">HIGH PRESSURE HAZARD!</p> <ul style="list-style-type: none"> • Avoid skin contact with the high pressure diesel fuel spray caused by a fuel system leak such as a broken fuel injection line. High pressure fuel can penetrate your skin and result in serious injury. If you are exposed to high pressure fuel spray, obtain prompt medical treatment. • NEVER check for a fuel leak with your hands. ALWAYS use a piece of wood or cardboard. Have your authorized Yanmar industrial engine dealer or distributor repair the damage. • Failure to comply could result in death or serious injury. <p style="text-align: right; font-size: small;">000008en</p>

Proper operation of the fuel injectors is required to obtain the optimum injection pattern for full engine performance. The EPA / ARB requires that you have the injectors inspected, cleaned and tested every 1500 hours. See your authorized Yanmar industrial engine dealer or distributor for this service.

Every 2000 Hours of Operation

Perform the following maintenance every 2000 hours of operation.

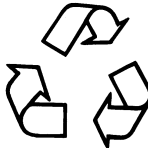
- **Check and Replace Fuel Hoses**

CAUTION

<p>Be environmentally responsible. Follow these procedures for hazardous waste disposal. Failure to follow these procedures may seriously harm the environment.</p> <ul style="list-style-type: none">• Follow the guidelines of the EPA or other governmental agency for the proper disposal of hazardous materials such as engine oil, diesel fuel and engine coolant. Consult the local authorities or reclamation facility.• NEVER dispose of hazardous materials irresponsibly by dumping them into a sewer, on the ground or into ground water or waterways.
<small>0000013en</small>

Check and Replace Fuel Hoses

Regularly check the fuel system hoses. If they are cracked or degraded, replace them. Replace the hoses at least every two years, or 2000 hours, whichever occurs first. Consult your authorized Yanmar industrial engine dealer or distributor to replace fuel system hoses.

TROUBLESHOOTING

If a problem occurs, stop the engine immediately. Refer to the SYMPTOM column in the Troubleshooting Chart to identify the problem.

CAUTION
<p>If any indicator fails to illuminate when the key switch is in the ON position, see your authorized Yanmar industrial engine dealer or distributor for service before operating the engine.</p> <p style="text-align: right;">0000028en</p>

CAUTION
<p>If any indicator illuminates during engine operation stop the engine immediately. Determine the cause and repair the problem before you continue to operate the engine.</p> <p style="text-align: right;">0000029en</p>

TROUBLESHOOTING CHART

SYMPTOM	PROBABLE CAUSE	ACTION	REFER TO
Indicator Turns On - Engine Running			
Engine oil pressure indicator (If equipped)	<ul style="list-style-type: none"> Low level of engine oil Too high an oil level 	<ul style="list-style-type: none"> Check and adjust oil level as necessary 	<i>Checking Engine Oil on page 33</i>
	<ul style="list-style-type: none"> Clogged engine oil filter 	<ul style="list-style-type: none"> Replace engine oil filter element 	<i>Replace Engine Oil on page 77</i>
Battery Indicator	<ul style="list-style-type: none"> Battery failure 	<ul style="list-style-type: none"> Check battery condition 	<i>Check Indicators on page 35</i>
	<ul style="list-style-type: none"> Faulty dynamo 	<ul style="list-style-type: none"> See authorized Yanmar industrial engine dealer or distributor 	—
Indicator Does Not Turn On - Key Switch is Turned to ON (OFF → ON)			
	<ul style="list-style-type: none"> Faulty electrical wiring or faulty indicator 	<ul style="list-style-type: none"> See authorized Yanmar industrial engine dealer or distributor 	—

TROUBLESHOOTING

SYMPTOM	PROBABLE CAUSE	ACTION	REFER TO
Indicator Stays On - Key Switch is Turned from Start to ON (START → ON)			
• Battery indicator stays On	• Faulty alternator	• See authorized Yanmar industrial engine dealer or distributor	—
• Engine oil pressure indicator stays On	• Faulty engine oil pressure switch		—
Engine Does Not Start			
• Starter motor operates but engine does not start	• No diesel fuel	• Refuel fuel system	<i>Filling the Fuel Tank on page 30</i>
	• Improper diesel fuel	• Replace with recommended diesel fuel	<i>Diesel Fuel Specifications on page 29</i>
	• Clogged fuel filter	• Replace fuel filter	<i>Drain the Fuel Tank and Replace Outlet Fuel Filter on page 82</i>
	• Poor fuel injection	• See authorized Yanmar industrial engine dealer or distributor	—
	• Compressed air leakage from intake / exhaust valves		—
	• Faulty engine stop solenoid (if equipped)		—
• Starter motor does not operate or rotates too slowly (engine can be turned manually)	• Battery needs charging	• Check electrolyte, recharge	<i>Check Battery (If Equipped) on page 70</i>
	• Faulty cable connection at battery terminals	• Clean terminals, retighten	—
	• Faulty starter switch	• See authorized Yanmar industrial engine dealer or distributor	—
	• Faulty starter motor		—
• Engine cannot be manually turned	• Inner parts seized or damaged		—
White or Black Exhaust Smoke			
• Black exhaust smoke	• Engine overloaded	• Reduce load	—
	• Clogged air cleaner element	• Clean element or replace	<i>Clean Air Cleaner Element on page 80</i>
	• Improper diesel fuel	• Replace with recommended diesel fuel	<i>Diesel Fuel Specifications on page 29</i>
	• Faulty spraying of fuel injection	• See authorized Yanmar industrial engine dealer or distributor	—
	• Excessive intake / exhaust valve clearance		—

SYMPTOM	PROBABLE CAUSE	ACTION	REFER TO
<ul style="list-style-type: none"> • White exhaust smoke 	<ul style="list-style-type: none"> • Improper diesel fuel 	<ul style="list-style-type: none"> • Replace with recommended diesel fuel 	<i>Diesel Fuel Specifications on page 29</i>
	<ul style="list-style-type: none"> • Faulty spray pattern of fuel injection 	<ul style="list-style-type: none"> • See authorized Yanmar industrial engine dealer or distributor 	—
	<ul style="list-style-type: none"> • Fuel injection timing delay 		—
	<ul style="list-style-type: none"> • Engine burning oil 		—

TROUBLESHOOTING INFORMATION

If your engine does not operate properly, refer to the troubleshooting chart or consult your authorized Yanmar industrial engine dealer or distributor.

Supply the authorized Yanmar industrial engine dealer or distributor with the following information:



- Model name and serial number of your engine
- The driven machine type (tractor, generator, skid steer loader), manufacturers name, model and serial number
- How long the engine has been in service (the number of engine hours or the number of calendar months)
- Operating conditions when problem occurs:
 - ◆ Engine rpm
 - ◆ Color of exhaust smoke
 - ◆ Type of diesel fuel
 - ◆ Type of engine oil
 - ◆ Any abnormal noises or vibration
 - ◆ Operating environment such as high altitude or extreme ambient temperatures, etc.
- Engine maintenance history and previous problems
- Other factors that contribute to the problem



This Page Intentionally Left Blank

LONG TERM STORAGE

This section of the *Operation Manual* describes the procedures necessary to place the engine into long term storage (six months or longer) and how to place it back into operation.

BEFORE YOU PLACE THE ENGINE IN LONG TERM STORAGE

 DANGER

<p>EXPLOSION HAZARD!</p> <ul style="list-style-type: none">• NEVER check the remaining battery charge by shorting out the terminals. This will result in a spark and may cause an explosion or fire. Use a hydrometer to check the remaining battery charge.• If the electrolyte is frozen, slowly warm the battery before you recharge it.• Failure to comply will result in death or serious injury.
000007en

 WARNING

<p>BURN HAZARD!</p> <ul style="list-style-type: none">• Batteries contain sulfuric acid. NEVER allow battery fluid to come in contact with clothing, skin or eyes. Severe burns could result. ALWAYS wear safety goggles and protective clothing when servicing the battery. If contact with the skin and / or eyes should occur, flush with a large amount of water and obtain prompt medical treatment.• Failure to comply could result in death or serious injury.
000007en

LONG TERM STORAGE

CAUTION



FLYING OBJECT HAZARD!

- **ALWAYS** wear eye protection when servicing the engine and when using compressed air or high-pressure water. Dust, flying debris, compressed air, pressurized water or steam may injure your eyes.
- Failure to comply may result in minor or moderate injury.

000003en

CAUTION

Protect the air cleaner, turbocharger (if equipped) and electric components from damage when you use steam or use high-pressure water to clean the engine.

000014en

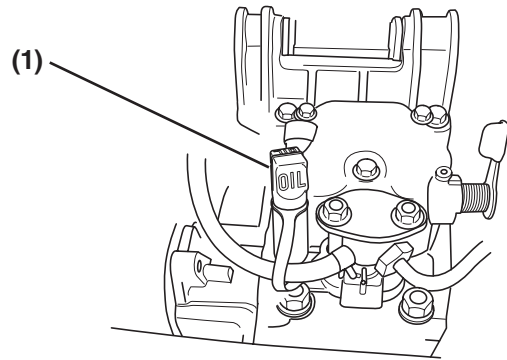

0001581

Figure 1

- (b) Add 2 cc of engine oil to the oil port (Figure 2, (1)).

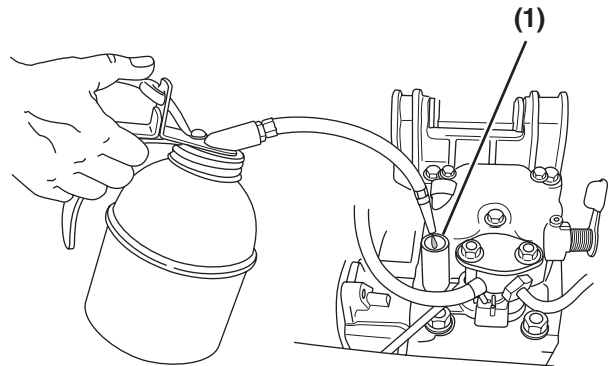

0001580

Figure 2

1. Perform the next Periodic Maintenance procedure. For example, if there are 10 hours before the 200 hour maintenance, you should do the maintenance before you place the engine in storage. *See the Periodic Maintenance Schedule on page 68.*
2. Start the engine. Allow the engine to idle, or run without load if there is no idle position in your application, for approximately 3 minutes and then stop the engine.
3. L48V Engines Only -
 - (a) Remove the oil plug (Figure 1, (1)).

- (c) Reinstall the oil plug (Figure 1, (1)).
4. Drain the engine oil while the engine is still warm and fill with new oil. *See Replace Engine Oil on page 77.*

5. Recoil start engines:
 - (a) Push the decompression lever down and hold it while slowly pulling the recoil starter 2 or 3 times. Do not start the engine.
 - (b) Pull the decompression lever up. Pull the recoil starter slowly and stop when there is resistance. This procedure closes the intake and exhaust valves in the compression position and helps prevent rust.
6. Electric start engines:
 - (a) Set the decompression lever at the non-compression position. Do not move the speed control lever to the START or RUN position.
 - (b) Turn the key to the start position and turn the engine for 2 to 3 seconds. Do not start the engine.
 - (c) Pull the decompression lever up.
7. Drain the fuel tank or make sure it is completely full.
8. Protect the air cleaner, muffler and electrical components (dynamo, starter motor, switches) from water and dust.
9. Disconnect the negative (-) battery cable to prevent the battery from discharging.
10. Check the battery fluid and add distilled water as required.
11. Charge the battery once a month during storage.
12. Clean the engine and store it in a dry place.

RETURNING THE ENGINE TO SERVICE

1. Perform the *Daily Checks on page 34*.
2. Start the engine. Allow the engine to idle, or run without load if there is no idle position in your application, for approximately 5 to 10 minutes while you check for:
 - (a) proper oil pressure.
 - (b) fuel, engine oil, or coolant leaks.
 - (c) proper operation of the indicators and / or gauges (if equipped).
3. Avoid prolonged operation at minimum or maximum engine speeds and loads for the remainder of the first hour of operation.

This Page Intentionally Left Blank

SPECIFICATIONS

GENERAL

Description of Model Number

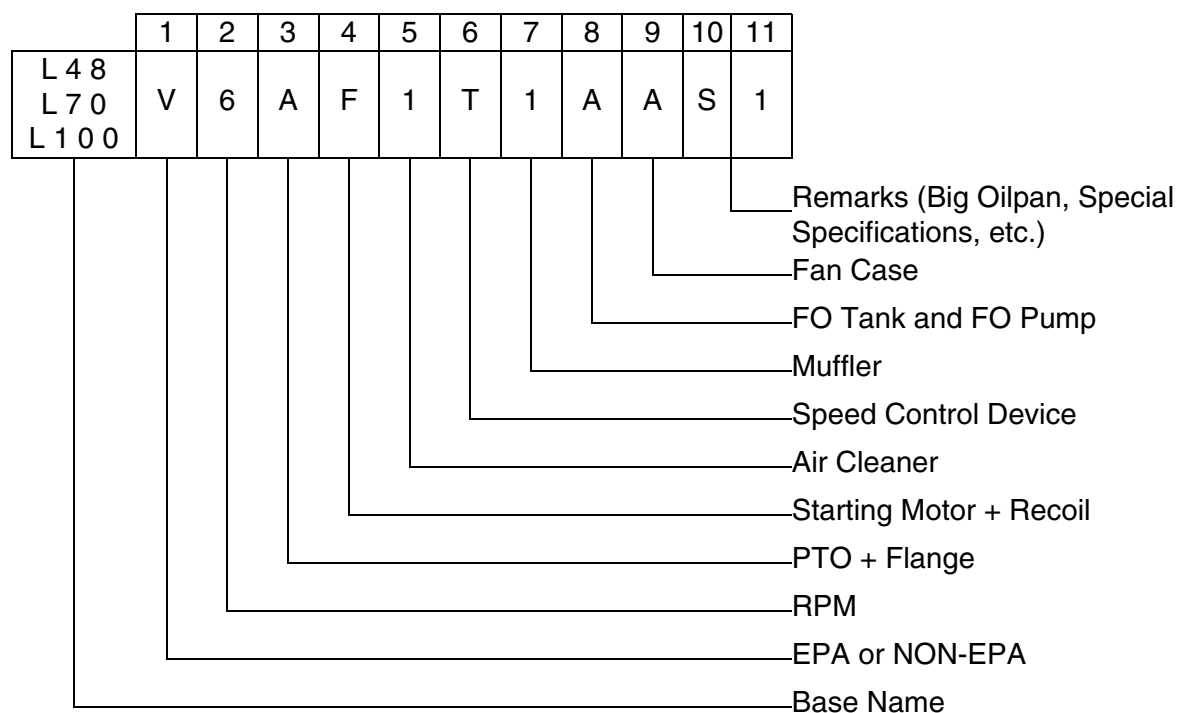

Engine Speed Specifications

AVAILABLE ENGINE SPEED	INTENDED USES
2500 ~ 3450 rpm (min ⁻¹)	Agricultural, Constructive, Industrial Machines
3600 rpm (min ⁻¹)	Generator Sets, Pumps

SPECIFICATIONS

Engine General Specifications

Type	Vertical, Air Cooled, 4-Cycle Diesel Engine
Combustion System	Direct Injection
Starting System	Electric Starting and/or Recoil Starting
Cooling System	Fan on Flywheel
Lubricating System	Forced Lubrication With Trochoid Pump
Direction of Rotation	Counterclockwise Viewed from PTO Side

Notes:

1. The information described in *Principal Engine Specifications* is for a “standard” engine. To obtain the information for the engine installed in your driven machine, please refer to the manual provided by the driven machine manufacturer.
2. Engine rating conditions are as follows (SAE J1349, ISO 3046/1):
 - Atmospheric Condition: Room temperature 77°F (25°C), Atmospheric pressure 29.53 in Hg (100 kPa, 750mm Hg), Relative humidity 30%
 - Fuel Temperature at Fuel Injector Pump Inlet: 104°F (40°C)
 - With Cooling Fan, Air Cleaner, Muffler: Yanmar Standard
 - After Engine Break-In Period. Output Allowable Deviation: ± 3%
 - 1 PS = 0.7355 kW
 - 1 hp SAE (Society of Automotive Engineers) = 0.7457 kW

PRINCIPAL ENGINE SPECIFICATIONS

Engine Specifications

Engine Model		L48V		L70V		L100V	
Type		4-stroke, Vertical Cylinder, Air-Cooled Diesel Engine					
No. of Cylinders		1					
Bore x Stroke		2.76 x 2.24 in (70 x 57 mm)		3.07 x 2.64 in (78 x 67 mm)		3.39 x 2.95 in (86 x 75 mm)	
Displacement		13.4 cu. in (0.219 L)		19.5 cu. in (0.320 L)		26.5 cu. in (0.435 L)	
Continuous Rated Output	rpm (min ⁻¹)	3600	3450	3600	3600	3200	2500
	hp SAE	4.0	3.8	5.8	8.3	7.8	6.7
	kW	3.0	2.8	4.3	6.2	5.8	5.0
	PS	4.1	3.8	5.9	8.4	7.9	6.8
Max. Rated Output (Net)	rpm (min ⁻¹)	3600	3450	3600	3600	3200	2500
	hp SAE	4.4	4.2	6.4	9.1	8.7	7.4
	kW	3.3	3.1	4.8	6.8	6.5	5.5
	PS	4.5	4.2	6.5	9.3	8.8	7.5
High Idling	rpm (min ⁻¹)	3800±30	3450±30	3800±30	3800±30	3450±30	2700±30
Engine Weight (Dry)	with Electric Start	70.5 lb (32.0 kg)		90.4 lb (41.0)		118 lb (53.5 kg)	
	without Electric Start	59.5 lb (27.0 kg)		79.4 lb (36.0)		107 lb (48.5 kg)	
Cooling System		Forced Air by Flywheel Fan					
Lubricating System		Forced Lubrication with Trochoid Pump					
Starting System		Electric Start / Recoil Start					
Dimensions (L x W x H)		13.1 x 15.1 x 16.4 in (332 x 384 x 417 mm)		14.9 x 16.6 x 17.8 in (378 x 422 x 453 mm)		16.2 x 18.5 x 19.4 in (412 x 471 x 494 mm)	
Engine Oil Pan Capacity	Dipstick Upper Limit	0.85 qt (0.8 L)		1.11 qt (1.05 L)		1.7 qt (1.6 L)	
	Dipstick Lower Limit	0.58 qt (0.55 L)		0.69 qt (0.65 L)		1.06 qt (1.0 L)	
Fuel Tank Capacity (Recommended)		2.0 qt (1.9 L)		2.85 qt (2.7 L)		5.0 qt (4.7 L)	

This Page Intentionally Left Blank